



**LABCONCO CORPORATION**  
8811 Prospect Avenue  
Kansas City, MO 64132  
(800) 821-5525, (816) 333-8811  
(816) 363-0130 fax  
[labconco@labconco.com](mailto:labconco@labconco.com)

# User's Manual

## FreeZone<sup>®</sup> Benchtop Freeze Dryers

### Models

70020\*\*\*\* 2.5L -50°C Series  
71020\*\*\*\* 2.5L -84°C Series  
70040\*\*\*\* 4.5L -50°C Series  
71040\*\*\*\* 4.5L -84°C Series  
72040\*\*\*\* 4.5L -105°C Series  
70080\*\*\*\* 8L -50°C Series

To receive important product updates,  
complete your product registration card  
online at [register.labconco.com](http://register.labconco.com)

**Please read the User's Manual before operating the equipment.**

Copyright © 2018 Labconco Corporation. The information contained in this manual and the accompanying products are copyrighted and all rights reserved by Labconco Corporation. Labconco Corporation reserves the right to make periodic design changes without obligation to notify any person or entity of such change.

## **Warranty**

Labconco Corporation provides a warranty to the original buyer for the repair or replacement of parts and reasonable labor as a result of normal and proper use of the equipment with compatible chemicals. Broken glassware and maintenance items, such as filters, gaskets, light bulbs, finishes and lubrication are not warranted. Excluded from warranty are products with improper installation, erratic electrical or utility supply, unauthorized repair and products used with incompatible chemicals.

The warranty for FreeZone® Freeze Dry Systems will expire one year from date of installation or two years from date of shipment from Labconco, whichever is sooner. Warranty is non-transferable and only applies to the owner (organization) of record.

Buyer is exclusively responsible for the set-up, installation, verification, decontamination or calibration of equipment. This limited warranty covers parts and labor, but not transportation and insurance charges. If the failure is determined to be covered under this warranty, the dealer or Labconco Corporation will authorize repair or replacement of all defective parts to restore the unit to operation. Repairs may be completed by 3<sup>rd</sup> party service agents approved by Labconco Corporation. Labconco Corporation reserves the rights to limit this warranty based on a service agent's travel, working hours, the site's entry restrictions and unobstructed access to serviceable components of the product.

Under no circumstances shall Labconco Corporation be liable for indirect, consequential, or special damages of any kind. This warranty is exclusive and in lieu of all other warranties whether oral, or implied.

## **Returned or Damaged Goods**

Do not return goods without the prior authorization from Labconco. Unauthorized returns will not be accepted. If your shipment was damaged in transit, you must file a claim directly with the freight carrier. Labconco Corporation and its dealers are not responsible for shipping damages.

The United States Interstate Commerce Commission rules require that claims be filed with the delivery carrier within fifteen (15) days of delivery.

## **Limitation of Liability**

The disposal and/or emission of substances used in connection with this equipment may be governed by various federal, state, or local regulations. All users of this equipment are required to become familiar with any regulations that apply in the user's area concerning the dumping of waste materials in or upon water, land, or air and to comply with such regulations. Labconco Corporation is held harmless with respect to user's compliance with such regulations.

## **Contacting Labconco Corporation**

If you have questions that are not addressed in this manual, or if you need technical assistance, contact Labconco's Customer Service Department or Labconco's Product Service Department at 1-800-821-5525 or 1-816-333-8811, between the hours of 7:30 a.m. and 5:30 p.m., Central Standard Time.

---

# TABLE OF CONTENTS

<b>CHAPTER 1: INTRODUCTION</b>	1
Intended Use	1
Typographical Conventions	1
Safety Information	2
Freeze Dry Process	3
Freeze Dry Rates	3
Freeze Dry Capacity	4
Samples Containing Volatile Substances	5
About This Manual	5
<b>CHAPTER 2: PREREQUISITES</b>	6
Electrical Requirements	6
Location Requirements	7
Vacuum Pump Requirements	7
Chamber or Manifold Requirements	7
<b>CHAPTER 3: GETTING STARTED</b>	8
Unpacking Your Freeze Dryer	8
Freeze Dryer Components	9
Setting Up Your Freeze Dryer	9
Component Identification	10
Vacuum Pump Connection	11
Electrical Connection	12
Baffle Installation	12
Drying Chamber or Manifold Installation	13
Chemical Resistance of Freeze Dryer Components	14
Solvent Safety Precautions	16
<b>CHAPTER 4: LYO-WORKS™ OPERATING SYSTEM</b>	17
Control Panel	17
Initial Power Up	18
Touch Screen Operation	18
Home Screen	18
Main Menu Icons	19
Moving Between Menu Screens	19
Function Indicator Bar	19
System Parameters Display	19
Operation Buttons (Auto, Collector, Vacuum)	20

Programs Screen	21
Data Logging Screen	23
Settings Screen	24
Language	24
Time & Date	24
Units	25
Security	25
Alerts	25
Configure Email Settings	26
Maintenance	28
Vacuum Pump Settings	28
Refrigeration System Settings	28
Freeze Dryer Line Voltage Offset	28
Vacuum Pump Protection	28
Calibration	29
Display	30
Network	31
Data Logs	31
Sensors Screen	32
Drying Accessory Screen	32
End Point Detection Screen	33
Help Screen	34
About	34
Diagnostics	34
Resources	35
Backup/Restore	35
<b>CHAPTER 5: USING YOUR FREEZE DRYER</b>	<b>36</b>
Operation Checklist	36
Vacuum Pump Ballast Setting	37
Operating the Freeze Dryer	37
Auto Start-Up	37
Manual Start-Up	37
Setting the Operating Vacuum Level	37
Pre-Freezing Samples	38
Adding Sample	39
Starting a Program	40
Shut Down	40
Defrosting	40
Alerts	41
Power Fail	41
Line Voltage Range	42
Collector Temp	42
Collector Moisture	42
Service Vacuum Pump	42
Vacuum Leak	42
Vacuum Set Point	42
Status Email Messages	42

End Point Detection	43
Shelf Temp Variation	43
Shelf Temp Set Point	43
Power Fail	43
Program Complete	43
Export a Data Log File	43
Download a Data Log File via Ethernet	43
Copy a Program	44
<b>CHAPTER 6: MAINTAINING YOUR FREEZE DRYER</b>	<b>45</b>
Service Safety Precautions	45
Routine Maintenance Schedule	45
<b>CHAPTER 7: TROUBLESHOOTING</b>	<b>47</b>
Vacuum Pump	47
Gaskets, Tubing, Connections, Sample Valves	48
System Components & Collector Chamber Isolation	50
Refrigeration Module Operation	52
<b>APPENDIX A: FREEZE DRYER COMPONENTS</b>	<b>53</b>
<b>APPENDIX B: FREEZE DRYER DIMENSIONS</b>	<b>60</b>
<b>APPENDIX C: FREEZE DRYER SPECIFICATIONS</b>	<b>63</b>
Electrical Specifications	63
Environmental Conditions	64
<b>APPENDIX D: FREEZE DRYER ACCESSORIES</b>	<b>65</b>

---

# CHAPTER 1

## INTRODUCTION

Congratulations on your purchase of a Labconco FreeZone® Freeze Dry System, which is designed for laboratory lyophilization procedures. The refrigerant used in the refrigeration system is HCFC-free so it will not endanger the environment. The unit is easy to install and maintain. Proper care and maintenance of this product will result in many years of dependable service.

### Intended Use

The Labconco Freeze Dryers described in this manual are intended for laboratory use to facilitate the lyophilization process.

### Typographical Conventions

Recognizing the following typographical conventions will help you understand and use this manual:

- Book, chapter, and section titles are shown in italic type (e.g., *Chapter 3: Getting Started*).
- Steps required to perform a task are presented in a numbered format.
- Comments located in the margins provide suggestions, reminders, and references.
- Critical information is presented in boldface type in paragraphs that are preceded by the exclamation icon. Failure to comply with the information following an exclamation icon may result in injury to the user or permanent damage to your Freeze Dryer.
- Important information is presented in capitalized type in paragraphs that are preceded by the pointer icon. It is imperative that the information contained in these paragraphs be thoroughly read and understood by the user.

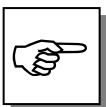

## Safety Information



### For Hydrocarbon Refrigeration Only See Below:

- **DANGER** – Risk of fire or explosion. Flammable refrigerant used. Do not use mechanical devices to defrost refrigerator. Do not puncture refrigerant tubing.
- **DANGER** – Risk of fire or explosion. Flammable refrigerant used. To be repaired only by trained service personnel.
- **WARNING** – Keep all ventilation openings in the enclosure or, in the structure for building-in, clear of obstruction.
- **CAUTION** – Risk of fire or explosion. Flammable refrigerant used. Consult repair manual/owner's guide before attempting to service this product. All safety precautions must be followed.
- **CAUTION** – Risk of fire or explosion. Dispose of properly in accordance with federal or local regulations. Flammable refrigerant used.
- **CAUTION** – Risk of fire or explosion due to puncture of refrigerant tubing. Follow handling instructions carefully. Flammable refrigerant used.



### Replacement components and servicing

- Component parts shall be replaced with like components.
- Servicing shall be performed by authorized service personnel to minimize the risk of possible ignition due to incorrect parts or improper service.

## Freeze Dry Process

Freeze drying is an important process in sample preparation and for the preservation and storage of biologicals, pharmaceuticals and foods. Of the various methods of dehydration, freeze drying (lyophilization) is especially suited for substances that are heat sensitive. Other than food processing (e.g., coffee, whole dinners), freeze drying has been extensively used in the development of pharmaceuticals (e.g., antibiotics) and preservation of biologicals (e.g., proteins, plasma, viruses and cell lines). The nondestructive nature of this process has been demonstrated by the retention of viability in freeze dried viruses and microorganisms.

Freeze drying is a process whereby water or other solvent is removed from frozen material by converting the frozen water directly into vapor without the intermediate formation of liquid water. The basis for this sublimation process involves the absorption of heat by the frozen sample in order to vaporize the ice; the use of a vacuum pump to enhance the removal of water vapor from the surface of the sample; the transfer of water vapor to a collector; and the removal of heat by the collector in order to condense the water vapor. In essence, the freeze dry process is a balance between the heat absorbed by the sample to vaporize the ice and the heat removed from the collector to convert the water vapor into ice.

## Freeze Dry Rates

The efficiency of the Freeze Drying process is dependent upon the surface area and the thickness of the sample, the collector temperature and vacuum obtained, the eutectic point and solute concentration of the sample. It is important to remember these factors when trying to obtain efficient utilization of your Freeze Dry system. A listing of selected materials and their approximate drying times are shown in Table 1 for your reference.

**Table 1**

SAFE TEMPERATURE AND DRYING TIMES FOR SELECTED MATERIALS			
Material 10mm Thick	Safe Temperature °C	Collector Temperature °C	Hours (Approx.)
Milk	-5	-40	10
Urea	-7	-40	10
Blood Plasma	-10 to -25	-40	16
Serum	-25	-40	18
Vaccinia	-30 to -40	-50	22
Influenza Vaccine	-30	-50	24
Human Tissue	-30 to -40	-50	48
Vegetable Tissue	-50	-80	60

\*Total sample quantities are contingent on various freeze dryer capacities.



## Chapter 1: Introduction

---

Up to the point of overloading the system, the greater the surface area of the sample, the faster the rate of freeze drying. By contrast, for a given surface area, the thicker the sample the slower the rate of freeze drying. This is based on the fact that the heat of sublimation is usually absorbed on one side of the frozen sample and must travel through the frozen layer to vaporize water at the other surface. In addition, as the sample is freeze dried, the water vapor must travel through the layer of dried material. The thicker the sample, the greater the chance that the dried layer may collapse which would cause an additional decrease in the rate of freeze drying.

The surface area and thickness of the sample can usually be ignored when each sample contains only a few milliliters. However, for larger volumes, the samples should be shell frozen to maximize the surface area and minimize the thickness of the sample. The volume of the freeze dry flask should be two to three times the volume of the sample.

In order for lyophilization to occur, ice must be removed from the frozen sample via sublimation. This is accomplished by the collector and the vacuum pump. The collector, which should be at least 15 to 20°C colder than the eutectic temperature (melting temperature) of the sample, traps vapor as ice. Since the vapor pressure at the collector is lower than that of the sample, the flow of water vapor is from the sample to the collector. Since this vapor diffusion process occurs very slowly under normal atmospheric conditions, a good vacuum is essential to maintain an efficient rate. In many applications, the maintenance of a vacuum of 0.133 mbar or less is recommended.

The rate of freeze drying is directly proportional to the vapor pressure and the vapor pressure is dependent upon both eutectic temperature and solute concentration of the sample. For example, a solution of sodium chloride and water would freeze dry at a slower rate than pure water. The eutectic temperature of a sodium chloride solution is about -21°C and at this temperature the vapor pressure is about 1/16 that of water at 0°C. Although the eutectic temperature is not dependent upon the concentration of sodium chloride, the vapor pressure of the water would decrease as the concentration of sodium chloride increased. This is due to the fact that as the solute concentration increases, less of the surface area of the frozen sample is occupied by water. In general, most solutions or biological samples will have a eutectic temperature of -10 to -25°C. However, if the sample contains a simple sugar such as glucose or if the sample is animal or plant tissue, the eutectic temperature may be as low as -30° to -50°C.

## Freeze Dry Capacity

The volume of a sample that can be freeze dried at one time is related to factors discussed previously and the size and design of the freeze dry system. With any given instrument, the capacity is based on the surface area of the sample; the eutectic temperature and concentration of the sample; and the rate and amount of heat transferred to the frozen sample. Of these factors, the eutectic temperature is the most important factor in determining the amount of sample that can be freeze

dried at one time, particularly when flasks are used. This is because as the eutectic temperature decreases, the vapor pressure decreases but the rate of heat absorption by the sample does not change. This tends to promote melting of the sample, which leads to a marked increase in vapor pressure and ultimately overloads the collector and vacuum pump. Samples that have eutectic temperatures of  $-20^{\circ}\text{C}$  or lower should be placed on the freeze dry system one flask at a time so that the vacuum in the system may recover before adding another sample to the system. If the vacuum does not recover, the capacity of the freeze dry system has been exceeded and the sample should be removed.

If there is a problem with a particular type of sample melting when placed on the freeze dry system, dilution of the sample with more water or providing some insulation around the flask to decrease the rate of heat absorption by the sample may help. If the eutectic temperature of the sample is  $-40$  to  $-60^{\circ}\text{C}$ , the freeze dry system selected for use must be equipped with cascade type refrigeration so that the collector temperature can be cooled to below  $-75^{\circ}\text{C}$ , or a dry ice/solvent trap may be used between the collector and the vacuum pump.

## **Samples Containing Volatile Substances**

In certain cases the solvent in a sample to be freeze dried may contain volatile components such as acetonitrile, methanol, acetic acid, formic acid or pyridine. In addition to these substances having an effect on the eutectic temperature, they may increase the vapor pressure at the surface of the sample. Also, compared to water, they will require the absorption of less heat for sublimation to occur. Hence, samples that contain volatile substances will have a greater tendency to melt, particularly when placed in flasks or exposed to room temperature. If a sample containing a volatile substance tends to melt when placed on a freeze dry system, dilution of the sample with more water will help keep the sample frozen. For example, a 0.2M solution of acetic acid is much easier to freeze dry than a 0.5M solution.

## **About This Manual**

This manual is designed to help you learn how to install, use, and maintain your Freeze Dryer. Instructions for performing routine maintenance and making minor modifications to your Freeze Dryer are also included.

# CHAPTER 2

## PREREQUISITES

Before you install your Freeze Dryer, you need to prepare your site for installation. Carefully examine the location where you intend to install your Freeze Dryer. You must be certain that the area is level and of solid construction. An electrical source must be located near the installation site.

Carefully read this chapter to learn:

- Electrical supply requirements.
- Vacuum pump requirements.

Refer to *Appendix C: Freeze Dryer Specifications* for complete Freeze Dryer electrical and environmental conditions, specifications and requirements.

### Electrical Requirements

- 115V models
  - 20 Amp dedicated single phase circuit.
  - Properly grounded receptacle for NEMA 5-20P plug.

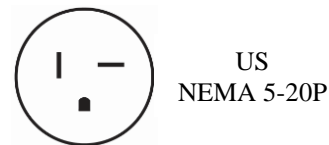

- 230V models
  - 15 Amp dedicated single phase circuit.
  - Properly grounded receptacle that matches the plug supplied with the unit, (230V models are supplied with one of the following plugs):

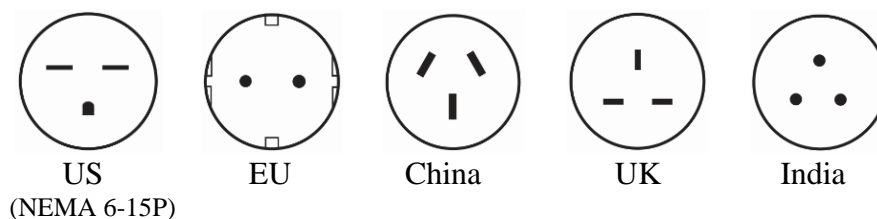

- If the plug does not match the available receptacle, remove the plug and replace it with an approved plug of the suitable style.



**Do not use any detachable power cord that is not adequately rated for the unit.**



**Frequency must agree with the serial tag rating. Improper frequency will damage the compressor.**

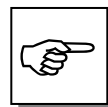

**ADDITIONAL APPLIANCES ON THE SAME CIRCUIT MAY CAUSE THE CURRENT TO EXCEED THE RATING OF THE CIRCUIT BREAKER OR FUSE.**

## Location Requirements

The Freeze Dryer should be located in an area that provides an unobstructed flow of air around the cabinet. This air cools the refrigeration system. The refrigeration system draws air through the rear panel and exhausts it through the sides. A minimum of 3" must be allowed between the back and both sides of the Freeze Dryer and adjacent wall surfaces. Restriction of airflow during operation could adversely affect performance.

Refer to *Appendix B: Freeze Dryer Dimensions* for dimensional drawings of the Freeze Dryer. The space for benchtop models must be large enough to accommodate the vacuum pump, which will be used with the Freeze Dryer.

## Vacuum Pump Requirements

A vacuum pump must be provided by the user. A vacuum pump with a displacement of 98 liters per minute and 0.007 mbar ultimate pressure is adequate for most samples. The inlet fitting on the vacuum pump must be suitable for 3/4" ID vacuum hose, which is provided. It is recommended that the vacuum pump is equipped with an exhaust filter to minimize oil mist exhausting from the vacuum pump. The operating vacuum level may be set on the Freeze Dryer. The higher the vacuum set point, the more likely it is that oil mist will be exhausted.

Vacuum pumps used with 115V models should be equipped with a 115V, 15 Amp NEMA 5-15P plug. Vacuum pumps used with 230V models should be equipped with a reverse IEC plug (included with 230V pumps purchased from Labconco). This will allow the vacuum pump to be plugged into the receptacle on the back panel of the freeze dryer.

## Chamber or Manifold Requirements

A freeze drying chamber or manifold is not included and must be purchased separately. These accessories allow samples to be attached to the Freeze Dryer. See *Chapter 3: Getting Started* for installation instruction.

---

# CHAPTER 3

## GETTING STARTED

Now that the site for your Freeze Dryer is properly prepared, you are ready to unpack, inspect, install and test your Freeze Dryer. Read this chapter to learn how to:

- Unpack and move your Freeze Dryer.
- Set up your Freeze Dryer.
- Connect the electrical supply source to your Freeze Dryer.
- Properly exhaust your Freeze Dryer.
- Safely use solvents with your Freeze Dryer.



**The FreeZone Benchtop Freeze Dryers weigh between 82 & 142 lbs (37-64 kg) depending on the model. If you must lift the Freeze Dryer manually, use at least two (2) persons and follow safe lifting guidelines.**

## Unpacking Your Freeze Dryer

Carefully unpack your Freeze Dryer and inspect it for damage that may have occurred in transit. If your Freeze Dryer is damaged, notify the delivery carrier immediately and retain the entire shipment intact for inspection by the carrier.

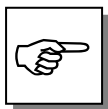

**DO NOT RETURN GOODS WITHOUT THE PRIOR AUTHORIZATION OF LABCONCO. UNAUTHORIZED RETURNS WILL NOT BE ACCEPTED.**

*The United States Interstate Commerce Commission rules require that claims be filed with the delivery carrier within fifteen (15) days of delivery.*

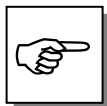

IF YOUR FREEZE DRYER WAS DAMAGED IN TRANSIT, YOU MUST FILE A CLAIM DIRECTLY WITH THE FREIGHT CARRIER. LABCONCO CORPORATION AND ITS DEALERS ARE NOT RESPONSIBLE FOR SHIPPING DAMAGE.

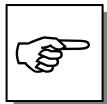

DO NOT DISCARD THE CARTON OR PACKING MATERIAL FOR YOUR FREEZE DRYER UNTIL YOU HAVE CHECKED ALL OF THE COMPONENTS AND INSTALLED AND TESTED THE FREEZE DRYER.

## Freeze Dryer Components

Verify that the components listed below are present and undamaged.

- (1) Freeze Dryer
- (1) Collector Chamber Lid Assembly
  - Acrylic Lid Assembly for -50C models
  - Stainless Steel Lid Assembly for -84C & -105C models

2.5L	4.5L	8L	Part #	Description	Comments
1	1	1	1089005	User's Manual	<i>USB Flash Drive</i>
1	1	1		Power Cord	<i>See parts list (Appendix A)</i>
1	1	1	7373450	Vacuum Hose	
2	2	2	1488800	Hose Clamp	
1			7419300	Baffle	<i>-84C Models Only</i>
	1		7208100	Baffle	<i>-84C &amp; -105C Models Only</i>
1	1	1	7205304	Drain Hose	

If you did not receive one or more of the components listed for your Freeze Dryer, or if any of the components are damaged, contact Labconco Corporation immediately for further instructions.

## Setting Up Your Freeze Dryer

After you verify receipt of the proper components, move your Freeze Dryer to the location where you want to install it. Then, follow the steps listed below.

# Component Identification



## Vacuum Pump Connection

A vacuum pump (as described in *Chapter 2: Prerequisites*) is required to operate your Freeze Dryer properly. The Freeze Dryer is equipped with a 3/4" ID vacuum hose for connecting the collector chamber to the vacuum pump.



**Make certain that the oil in the vacuum pump is at the proper level.**

1. Place the vacuum pump near the benchtop Freeze Dryer.
2. Remove protective caps from inlet and outlet ports.
3. Some vacuum pumps have inlet fittings that clamp to the pump. Place the centering ring with filter screen on the inlet fitting.
4. Place the hose barb fitting on top of the centering ring and secure with the clamp.
5. **CHECK THE VACUUM PUMP OIL LEVEL.** Fill the pump with oil so the level is between the lines on the sight gauge on the end of the pump housing.
6. Attach one end of the vacuum hose to the port on the back of the Freeze Dryer and the other end to the inlet port of the vacuum pump with the hose clamps provided. If necessary, cut the hose to proper length to allow for gentle bends without kinks.

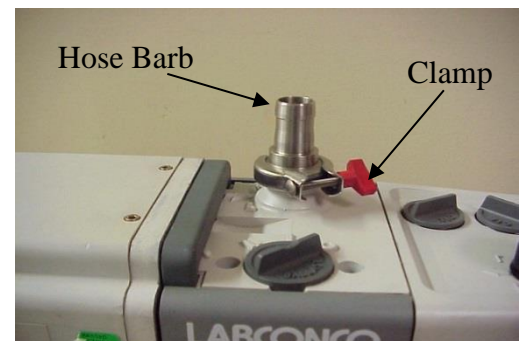
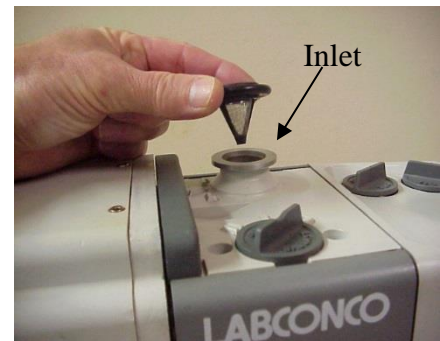



## Chapter 3: Getting Started

---

7. VERIFY THE VACUUM PUMP VOLTAGE SETTING AGREES WITH THE FREEZE DRYER VOLTAGE SHOWN ON THE SERIAL NUMBER LABEL. Reconfigure if necessary (see vacuum pump instructions).
8. Connect the vacuum pump power cord to the receptacle labeled “vacuum pump” on the back of the Freeze Dryer. Models rated for use on 230V have a reverse IEC receptacle for attaching the vacuum pump power cord.
9. If the vacuum pump has an ON/OFF switch, turn the switch ON. The vacuum pump will be controlled by the Freeze Dryer.

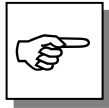

IT IS HIGHLY RECOMMENDED THAT AN OIL MIST EXHAUST FILTER BE INSTALLED ON ROTARY VANE VACUUM PUMPS TO MINIMIZE OIL MIST EXITING THE PUMP. AN OIL RETURN KIT CAN ALSO BE USED IN CONJUNCTION WITH THE EXHAUST FILTER TO RETURN TRAPPED OIL BACK TO THE VACUUM PUMP.

## Electrical Connection

Make sure that the outlet that you intend to use meets the voltage and amperage requirements listed on the serial tag of the Freeze Dryer. Plug the power cord into the receptacle on the back of the Freeze Dryer and plug the other end into a suitable power outlet. It will take approximately 90 seconds for the operating system to fully load.

## Baffle Installation

A cylindrical plastic baffle is shipped with **-84C & -105C** Freeze Dryers (Models 71020xxxx, 71040xxxx & 72040xxxx). The baffle is designed to evenly distribute collected ice over the entire collector coil. Proper positioning of the baffle is required to achieve maximum ice loading capabilities.

The baffle installs into the collector chamber with the flat flange upward. The arrow should point toward the front of the Freeze Dryer (as shown below).

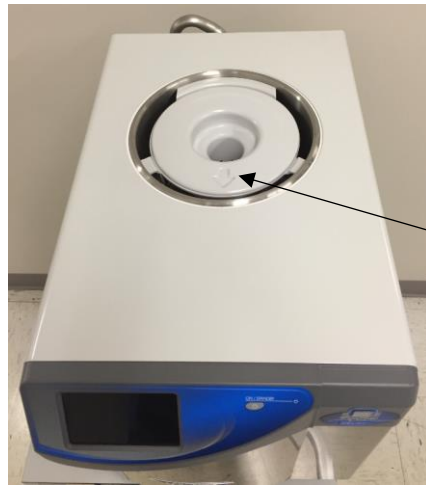

Arrow pointing forward

## Drying Chamber or Drying Manifold Installation

A drying chamber or drying manifold (purchased separately) may be positioned directly above the 3-inch hole in the collector chamber lid.

### 12 or 16 Port Drying Chamber Installation on Acrylic & Stainless Steel Lids

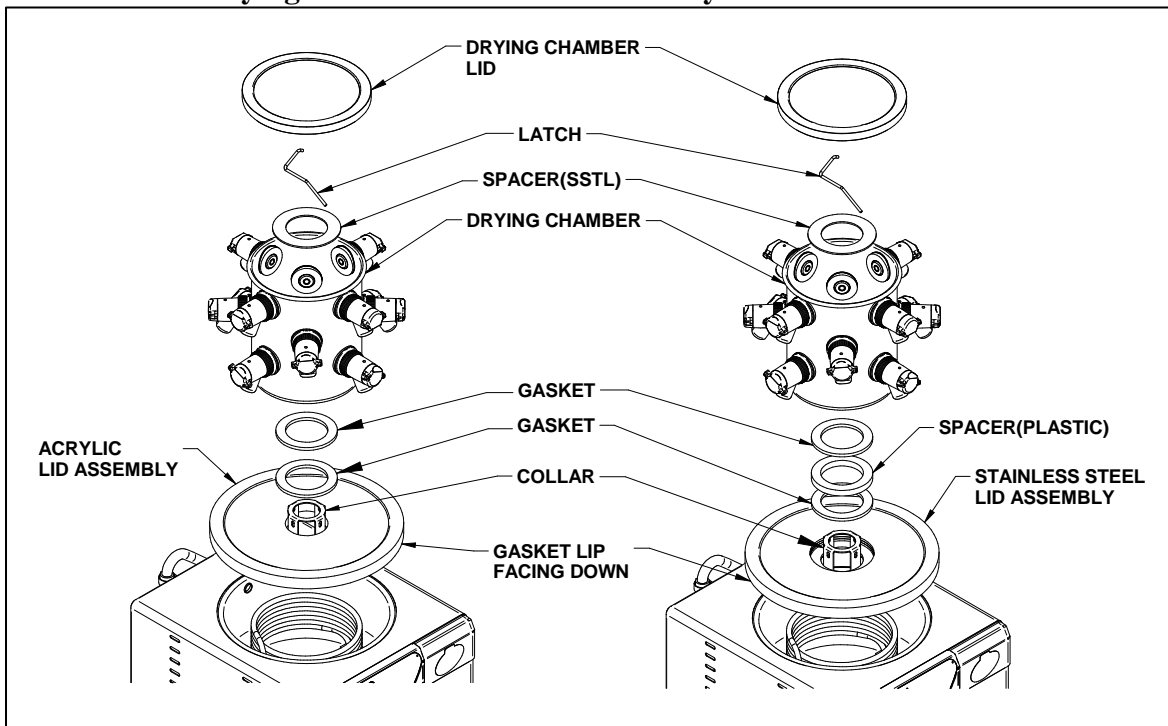

## Chapter 3: Getting Started

### 4 or 8 Port Manifold Installation on Acrylic or Stainless Steel Lids

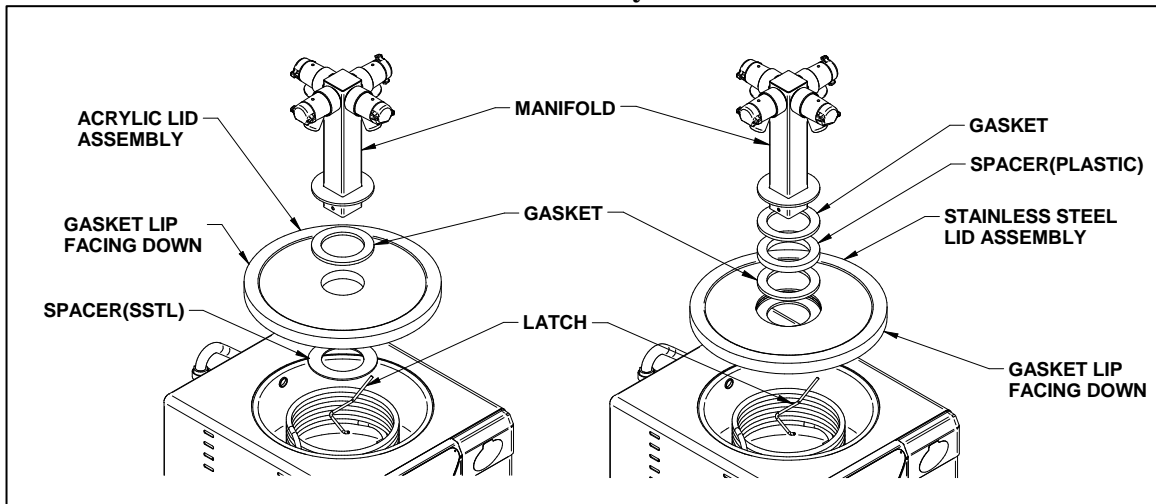

Clear Drying chambers come with their own bottom adapter plate that will be used in place of the collector chamber lid supplied with the Freeze Dryer.

### Clear Chamber Installation

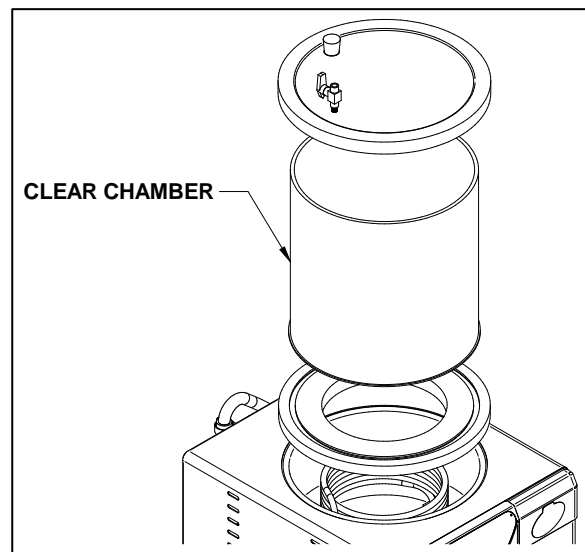

## Chemical Resistance of Freeze Dryer Components

The FreeZone Freeze Dry System is designed to be chemically resistant to most compounds that are commonly used in freeze drying processes. However, by necessity, the freeze dryer is comprised of a number of different materials, some of which may be attacked and degraded by certain chemicals. The degree of degradation is dependent on the concentration and exposure duration. Some of the

major components of the FreeZone Freeze Dry System that are susceptible to degradation are as follows:

Component	Material	Acids			Buffers		Solvents							
		Acetic Acid 20%	Formic Acid	Trifluoroacetic Acid (TFA)	Calcium Chloride	Sodium Phosphate	Acetone	Acetonitrile	Carbon Tetrachloride	Cyclohexane	Dioxane	Methyl t-Butyl Ether (BTBE)	Pyridine	
Valve Stem	Acetal	C	D	D	D		D							
Collector Lid	Acrylic			D			D	D	D					
Hoses, Gaskets & Valve Bodies	Neoprene	C	D	D			C	C	D	D	D	C	D	
Flask Top	Silicon Rubber		C	D		D			D	D	D	C	D	
Chamber & Fittings	Stainless Steel				C									

C – Moderate degradation; Limited use

D – Severe degradation; infrequent use recommended; immediate thorough cleaning required.

- Most common compounds used in freeze drying processes, if allowed to enter the vacuum pump, will degrade the oil and cause damage to the vacuum pump.
- Sugars and proteins typically will have minimal negative effect on any of the materials of construction.

When using compounds in the Freeze Dryer that are hostile to the materials of construction, it is imperative the equipment is thoroughly cleaned after use.

- Rubber and plastic components that have been exposed to damaging compounds should be removed and flushed with water.
- The oil in the vacuum pump should be checked often. It must be changed if it is cloudy, shows particles or is discolored. The useful life of vacuum pump oil can be extended if the vacuum pump is operated for an extended period of time after a freeze dry run. This allows contaminants to be purged from the hot oil. This must be done with the inlet to the pump blocked off to prevent air from free flowing through the pump. If the pump is operated at an elevated vacuum level (> 10mbar), oil may be expelled from the pump and damage could occur.

## Chapter 3: Getting Started

---

Another way to extend the life of the vacuum pump is to install an optional secondary trap in the line between the Freeze Dryer and the vacuum pump. Contact Labconco for ordering information.

With prudent maintenance the FreeZone Freeze Dry System will provide years of service. Warranty on the affected parts will be voided if maintenance has been obviously neglected. If you have questions about using specific compounds in the Freeze Dryer, contact Labconco Technical Service at 1-800-821-5525 or 816-333-8811 or e-mail: labconco@labconco.com.



### **Solvent Safety Precautions**

**Solvents used in the Freeze Dryer may be flammable or hazardous to your health. Use extreme caution and keep sources of ignition away from the solvents. When using flammable or hazardous solvents, the vacuum pump must be vented to or operated inside a fume hood.**

**Hazardous materials such as strong acids or bases, radioactive substances and volatile organics must be handled carefully and promptly cleaned up if spilled. If a sample is spilled in the collector chamber it must immediately be cleaned up.**

**WARNING: The disposal of substances used in connection with this equipment may be governed by various Federal, State or local regulations. All users of this equipment are urged to become familiar with any regulations that apply in the user's area concerning the dumping of waste materials in or upon water, land or air and to comply with such regulations.**

---

# CHAPTER 4

## LYO-WORKS™ OPERATING SYSTEM

After your Freeze Dryer has been installed as detailed in *Chapter 3: Getting Started*, read this chapter to learn how to:

- Operate the controls.
- Understand the display.



**Do not use the Freeze Dryer in a manner not specified by the manufacturer (refer to *Appendix C: Freeze Dryer Specifications*). The electrical protection properties of the Freeze Dryer may be impaired if the Freeze Dryer is used inappropriately.**

### Control Panel

The control panel for the Freeze Dryer is shown below with a description of its functions.



1. **Touch Screen Display** – Capacitive touch screen displays system operating parameters, set-up parameters and alarm messages. All user interface will take place via the touch screen.

## Chapter 4: Lyo-Works Operating System

2. **On / Standby Button** – If the display is illuminated pressing this button will put the display into low power mode (display backlight will be turned off). If the display is in low power mode, pressing this button will illuminate the display (Note: the display can also be brought out of low power mode by touching any location on the screen).
3. **On / Standby LED Indicator** – Blue LED indicator light to designate the current status of the system.
  - 1 flash per second = Initial power up (loading operating system)
  - Slow pulse = Touch screen in low power mode (screen timeout)
  - ON = Unit is plugged in and touch screen is in active mode
  - Off = Unit is unplugged

## Initial Power Up

When the Freeze Dryer is initially plugged into a power source, the On / Standby LED will begin flashing (1 flash per second). The display will remain OFF for the first 10 to 15 seconds, then the FreezeZone animated graphics will appear. It will take approximately 90 seconds for the operating system to fully load.

## Touch Screen Operation

### Home Screen

After initial power up, the Home screen will be displayed. Most of the general operation and system monitoring can be done from the Home screen.

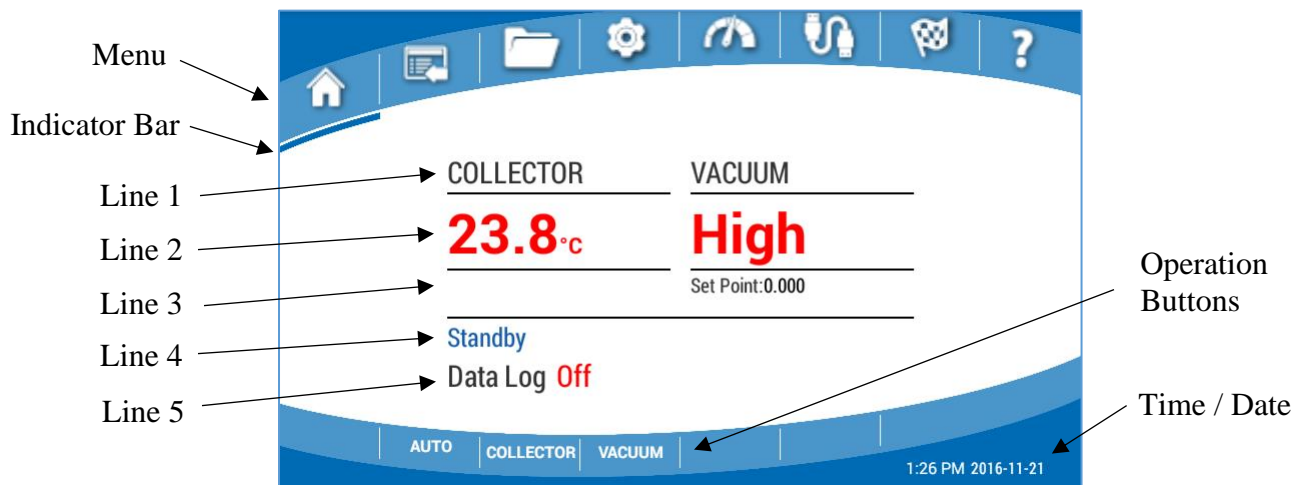

## Main Menu Icons

Menu icons are displayed across the top of the screen. Their descriptions from left to right are as follows:

1. Home
2. Programs
3. Data Logging
4. Settings
5. Sensors
6. Drying Accessory
7. End Point Detection
8. Help

## Moving Between Menu Screens

You can move between menu screens by either touching the menu icons or swiping across the screen from left to right or right to left.

The Following system parameters are displayed in the center portion of the screen:

## Function Indicator Bar

A thin blue indicator bar will appear under the icon of the menu screen that is currently being displayed. The same type of indicator bar will appear above the operation buttons to signify if each function is ON or OFF.

## System Parameters Display

### Line 1

**COLLECTOR & VACUUM HEADING** – Describes the measurement that is displayed directly below the text.

### Line 2

**COLLECTOR MEASUREMENT** - Displays the temperature of the collector coil in °C or °F (as selected in Settings). The value displayed will be **RED** if the temperature is:

- > -40° C (for -50C models)
- > -60° C (for -84C models)
- > -75° C (for -105C models)

The value displayed will be **GREEN** if the temperature is:

- ≤ -40° C (for -50C models)
- ≤ -60° C (for -84C models)
- ≤ -75° C (for -105C models)

**Note:** The refrigeration system of the -105C Freeze Dryers will periodically cycle OFF during normal operation. When this occurs the collector temperature will warm up briefly, then return back to its baseline temperature after the refrigeration system resumes operation.



## Chapter 4: Lyo-Works Operating System

---

**VACUUM MEASUREMENT** – Displays the Freeze Dryer vacuum level in mbar, Pa, or Torr (as selected in Settings). The display will read “High” if the vacuum level is  $> 5$  mbar. If the vacuum level is  $\leq 5$  mbar, a numerical value will be displayed. The value displayed will be **RED** if the vacuum is  $> 1.500$  mbar. The value displayed will be **GREEN** if the vacuum is  $\leq 1.500$  mbar.

### Line 3

**Vacuum Set Point** – Displays the current vacuum set point in mbar, Pa, or Torr (as selected in Settings) on the right hand side of Line 3.

### Line 4

**Operation Mode** – Indicates the current status of the Freeze Dryer. One of the following will always be displayed on this line:

1. **Standby** – Collector and Vacuum are both OFF
2. **Manual** – Collector and/or Vacuum are ON, but no Program is currently running.
3. **Program** – If a program is currently running this line will display the actual Program Name, Step #, and Time Remaining (hh:mm) in the current step of the program.
4. **Defrost** – Defrost will be displayed when the hot gas defrost function is turned ON.

### Line 5

**Data Logging Status** – **On** or **Off**

## Operation Buttons

Operation buttons are displayed across the bottom of the Home screen.

- **AUTO** – Use this button to initiate an auto start up sequence.  
When auto start is initiated the refrigeration system (collector) will be started immediately, and the vacuum pump will start when the collector temperature has cooled down to  $-40^{\circ}$  C.
- **COLLECTOR/DEFROST** – Use this button to turn the collector ON/OFF or turn the Defrost ON/OFF. The wording on this button will change from COLLECTOR to DEFROST depending on whether the defrost function is currently running. The defrost function will turn off automatically if the collector temperature reaches  $+60^{\circ}$ C or if defrost has been running for 2 hours.
- **VACUUM** – Use this button to turn the vacuum pump ON/OFF or change the vacuum set point value.

## Programs Screen

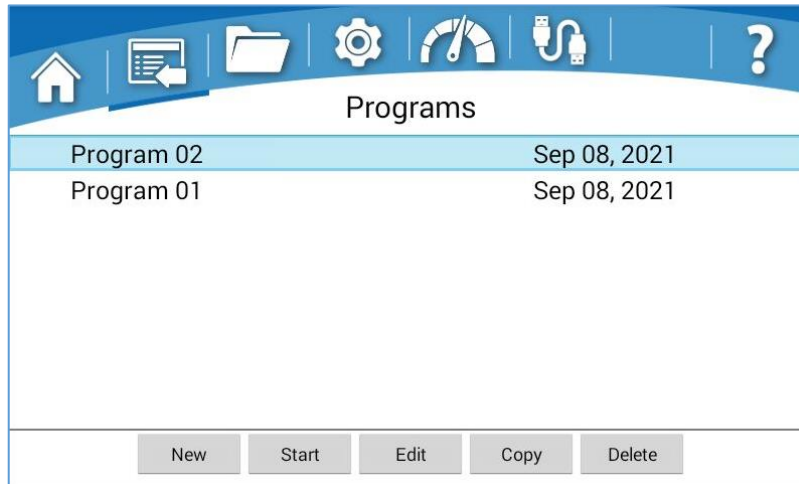

There are two accessories (Tray Dryer & Heated Product Shelves) that will run programs when connected to a Benchtop Freeze Dryer. The Programs screen will allow you to create and store programs that are used to control the shelf temperature and vacuum level. When no program has been selected the “New” button will be the only active button along the bottom of the screen. A program can be selected from the program list by pressing the program name. When a program has been selected, the program row will be highlighted (blue). With a program selected, the rest of the buttons along the bottom of the screen will become active (Start, Edit/View, Copy & Delete).

- **New** – Use this button to add a new program to the program list. The new program name will be defaulted to a two-digit sequential number (starting with “Program 01”) that will be incremented as new programs are added to the list (i.e., Program 02, Program 03...). The default name can be edited as desired in the New or Edit screen.
- **Start/Stop** – Use this button to start or stop a program. The wording on this button will change from “Start” to “Stop” depending on whether a program is currently running.

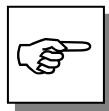

A DRYING ACCESSORY MUST BE ATTACHED TO THE FREEZE DRYER (VIA THE COMMUNICATION CABLE) TO RUN A PROGRAM. IF NO DRYING ACCESSORY IS ATTACHED TO THE FREEZE DRYER, THE START BUTTON WILL BE INACTIVE.

- **Edit/View** – Use this button to Edit or View the parameters of a saved program (the wording on this button will change from “Edit” to “View” depending on whether the program is locked or unlocked for editing).
- **Copy** – Use this button to Copy a selected program. The default name will be “*Program Name\_copy*”. The program name can be edited as desired.
- **Delete** – Use this button to delete a saved program from the list.

## Chapter 4: Lyo-Works Operating System

When a program is currently in progress, a “running man” icon will appear to the left side of the program name. If the running program is selected (highlighted), the “Stop” button will be active, and the “Delete” button will be inactive.

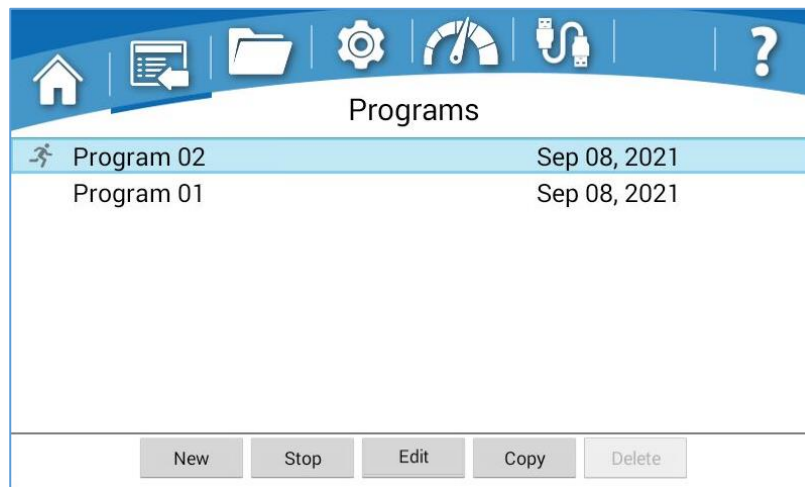

### “New” program

When the “New” button is selected, the following screen will be displayed.

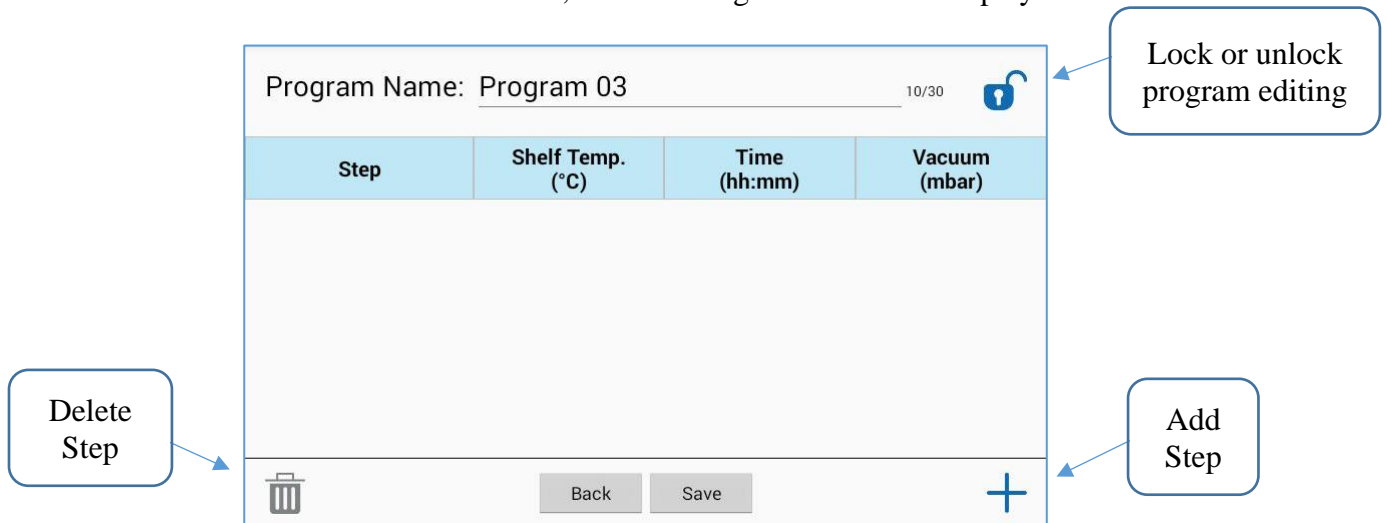

Pressing the program name field will allow you to edit the program name. The “Add” button will add a new Step to the program and take you through a series of screens to set the Shelf Temp., Time, and Vacuum. Values can be edited by pressing any of the cells. Pressing the “Delete” button will delete the selected step from the program. Changes will not be saved until the “Save” button is pressed. Pressing the “Back” button will return to the Programs screen without saving changes.

- **Shelf Temp.** - May be set anywhere from -20°C to +60°C in 1°C increments. (Note: The shelves have no cooling mechanism, therefore any cooling below room temperature is done by the frozen samples and the cooling from the sublimation process that is occurring).
- **Time** – This time represents how long the system will hold at the Shelf Temp. that has been programmed for each Step. The time can be set from 00:01 to 99:59 (1 min to 99 hrs 59 min). It can also be set to an indefinite amount of time, which is represented by the infinity symbol ( $\infty$ ).
- **Vacuum** – Vacuum control can be set from 0.000 to 1.500 mbar.

## Data Logging Screen

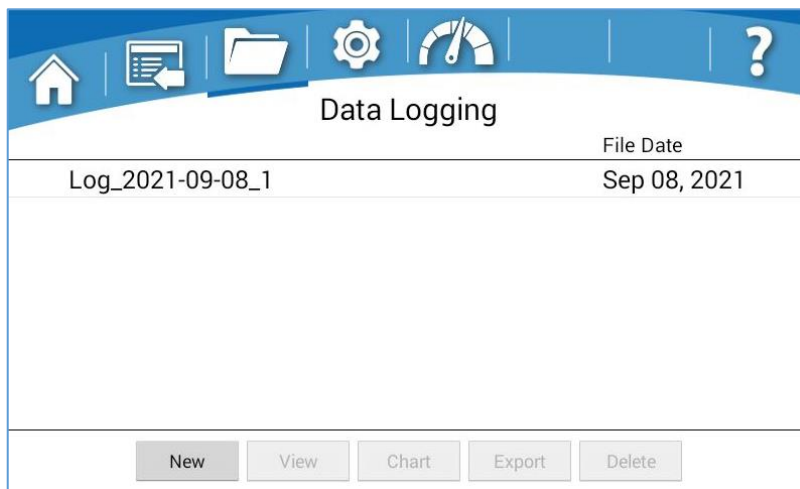

If no data log file has been selected the “New” button will be the only active button along the bottom of the screen. A data log file can be selected from the list by pressing the data log file name. When a data log file has been selected, the row will be highlighted (blue). With a data log file selected, the rest of the buttons along the bottom of the screen will become active (View, Chart, Export & Delete). If a data log file is currently running (collecting data), the “running man” icon will appear to the left of data log file name. If the currently running data log file is selected (highlighted), the Delete button will be inactive.

- **New/Stop** – Use this button to start a new data log file or to stop a running data log file. The wording on this button will change from “New” to “Stop” depending on whether a data log file is currently running. The new data log file name will be defaulted to the format shown above that includes the date the file was started and an incremental number to distinguish multiple files with the same date. The default name can be edited as desired in the New or View screen.
- **View** – Use this button to view the data from a saved data log file in table format.
- **Chart** – Use this button to view data from a saved data log file in chart format (1 temperature sensor & 1 vacuum sensor can be graphed at a time). Temperature and vacuum sensors can be selected from pop-up menus.

## Chapter 4: Lyo-Works Operating System

- **Export** – Use this button to export a selected data log file to a USB flash drive or computer via the USB port on the left side of the Freeze Dryer.
- **Delete** – Use this button to delete a saved data log file from the list.

### Settings Screen

Many of the user preferences may be configured from the Settings menu. Before operating the freeze dryer, you may want to configure some of the available preferences.

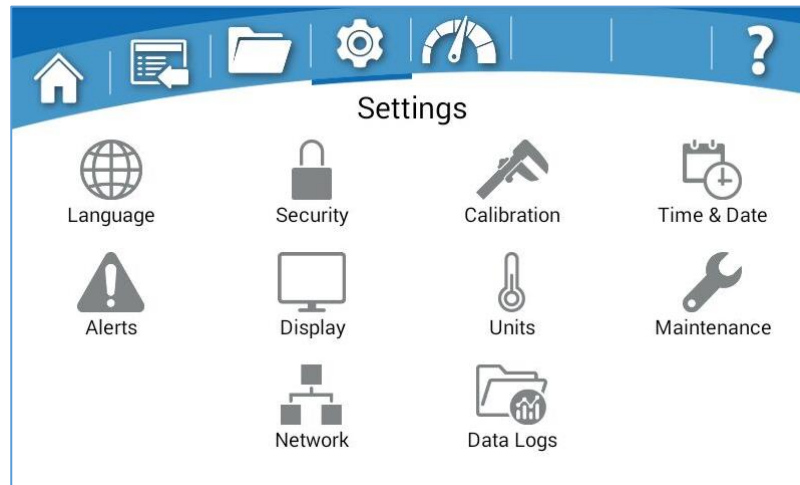

1. **Language** – Chose from 5 languages: English, Spanish, French, German, Italian
2. **Time/Date** – Chose Clock Format (12 or 24 hour), Set Time, Set Date for manually setting the time and date. The Auto Update time & date feature can be used if a valid network connection has been established. With Auto Update the following settings need to be entered:

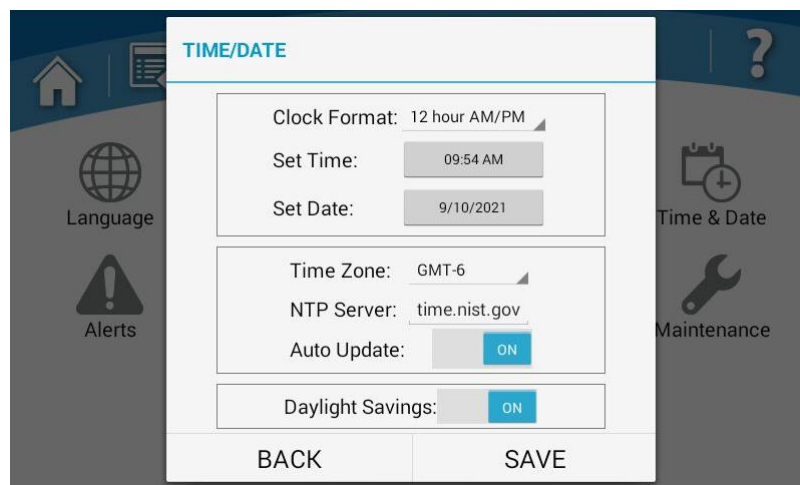

- **Time Zone** – Enter the Greenwich Mean Time (GMT) offset value for your location (integer value between -12 & +12).

- **NTP server** – Enter the “web address” (URL) of the NTP server (of your choice) that will provide clock synchronization data to the Freeze Dryer via the Ethernet connection.
  - **Daylight Savings (ON/OFF)** – When Auto Update is ON, this feature can be used to adjust the time for areas observing Daylight Savings Time (DST).
3. **Units** – Select your desired unit of measure for Temperature (°C, °F) and Vacuum (mbar, Pa, Torr)
  4. **Security** – A four-digit security code can be set that will require users to enter the code to gain access to selected screens. A security code will always be required to enter the “Security” screen.

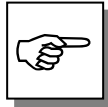

THE FACTORY DEFAULT SECURITY CODE IS “1234”

Security		
Security Code required to access or modify:		
<input type="checkbox"/>	System	
<input type="checkbox"/>	Programs	
<input type="checkbox"/>	Email Alerts	
<input type="checkbox"/>	Calibration	
<input type="checkbox"/>	Network	
<input type="checkbox"/>	Data Options	
Back	Set Code	OFF

- **System** – If the System security feature is selected (box checked), users will be required to enter the security code to gain access to the touch screen controls when the screen is reactivated from a screen timeout (sleep mode) or power failure (screen timeout described in the Settings/Display section).
  - **Programs, Email Alerts, Calibration, Network, Data Options** – Users will be required to enter the security code to gain access to each individual screen that has been selected (box checked).
5. **Alerts** – If a valid network connection has been established (via the Settings / Network screen) and Email Settings have been properly configured, alerts can be emailed to selected users, by entering the appropriate email address(es) and selecting the type of alerts that will be sent to each email address.

## Chapter 4: Lyo-Works Operating System

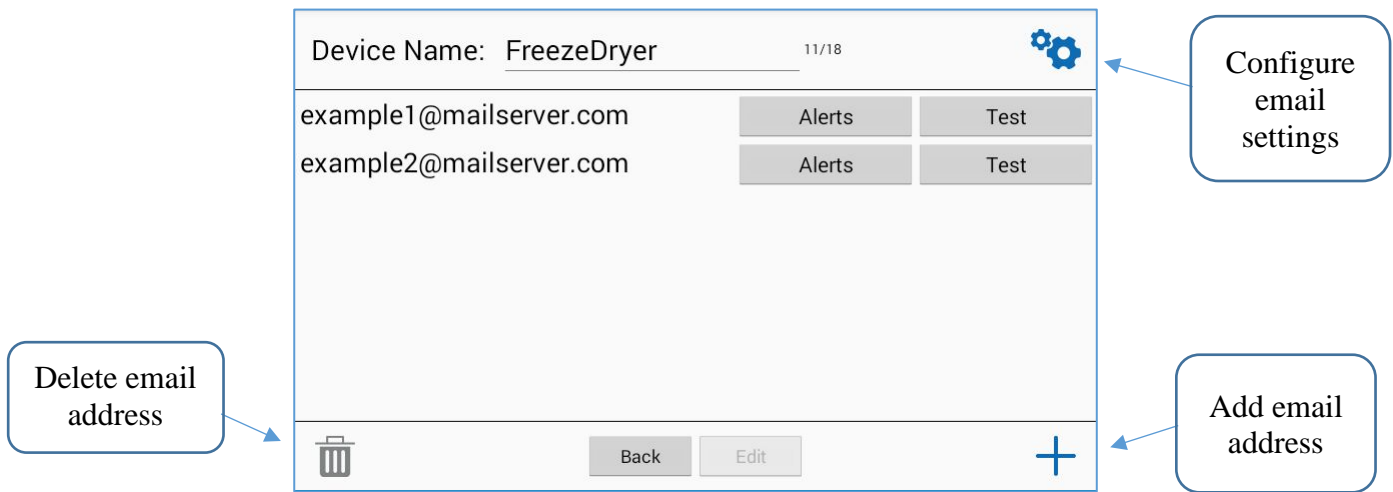

The Edit & Delete buttons will be inactive until an email address is selected from the list. When an email address has been selected, it will be highlighted (blue).

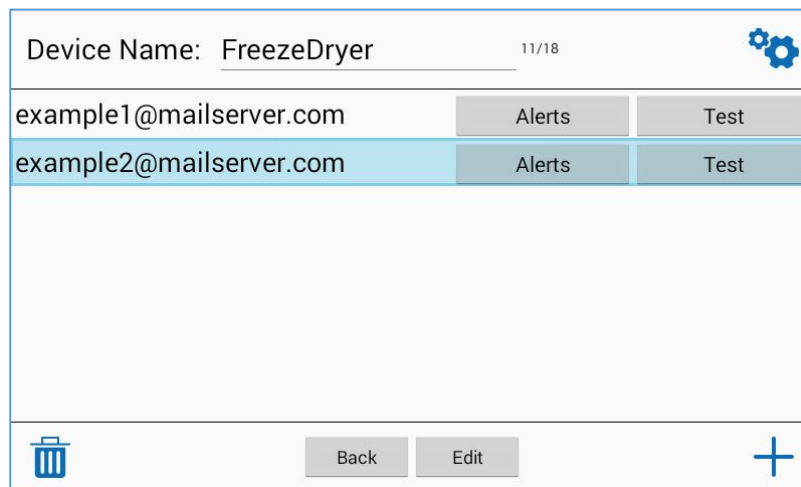

- **Add** – Use this button to add a new email address to the list.
- **Edit** – Use this button to edit an existing email address.
- **Delete** – Use this button to delete an existing email address.
- **Device Name** – The default name for this field will be “Freeze Dryer”. The name can be edited by pressing the name field.
- **Configure Email Settings** – Pressing this button will bring up the following screen, where the appropriate email settings can be entered.

The screenshot displays the 'EMAIL CONFIGURATION' dialog box. It contains the following fields and controls:

- SMTP Server:** A text input field.
- SMTP Username:** A text input field.
- SMTP Password:** A text input field.
- SMTP Port Number:** A text input field containing the value '0'.
- Encrypted Connection:** A toggle switch currently set to 'ON'.
- BACK** and **SAVE** buttons are located at the bottom of the dialog.

The background interface shows a list of devices, with 'example' entries and 'Test' buttons. At the bottom of the screen, there are 'Back' and 'Edit' buttons, and a plus sign icon.

If you do not know the proper information to enter into each of the SMTP fields, consult your IT personnel or email service provider.

After entering the appropriate information in all of the SMTP fields, press the Save button. The system will check the information entered into each field to make sure each entry is valid. If one or more invalid entries are found the following message will appear: *EMAIL SETTINGS ERROR – Unable to test email: (followed by more description depending on type of entry error)*.

If all the SMTP fields entered are valid, but the network connection is not working (or Ethernet cable is not connected) the following message will appear after pressing the Save button: *EMAIL SETTINGS ERROR – Network connection is not active*

- **Test** – After the Email Settings and Network Settings have been correctly entered, pressing this button will send a test email to the selected email address.
- **Alerts** – The type of alerts that will be sent to each individual email address can be customized. Pressing the Alerts button will bring up the following selection list. Alerts can be selected or deselected by pressing the check box in front of each alert. Scroll list up or down by swiping screen up or down. Alerts for the Freeze Dryer will be at the top of the list. Alerts for attached accessories (Tray Dryer or Heated Product Shelves) will appear at the bottom of the list.



## Chapter 4: Lyo-Works Operating System

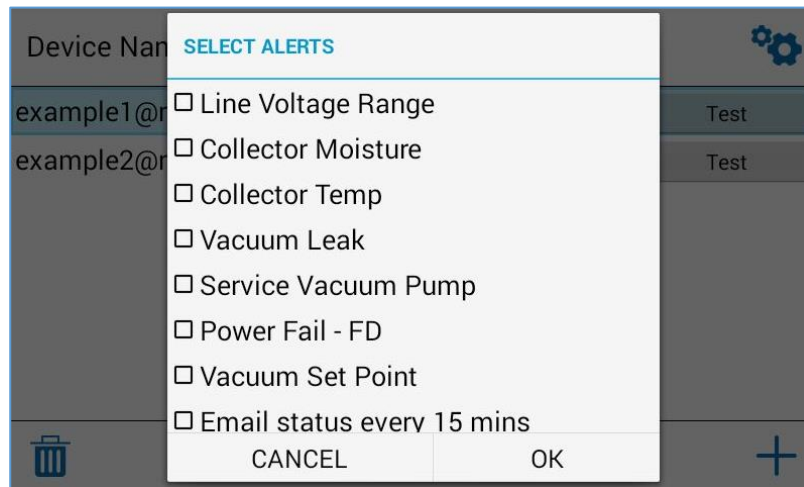

6. **Maintenance** – This screen contains data and settings pertaining to the operation hours and maintenance period for the vacuum pump and refrigeration system. Scroll up and down to view the entire page.
- **Line Voltage Offset** - These offset values determine the acceptable voltage range for electrical power supplied to the Freeze Dryer. If the supply line voltage is outside of the acceptable range, then the Line Voltage Range alert will be displayed. The default range is +/- 12.5% of the nominal rated voltage (115V or 230V depending on model). The LOW Line Voltage Offset can be adjusted from 0 to -10V (115V models) or 0 to -20V (230V models). The HIGH Line Voltage Offset can be adjusted from 0 to +10V (115V models) or 0 to + 20V (230V models). Scroll up and down to view the entire page.
  - **Vacuum Pump Protection** – If vacuum pump protection is turned ON, the vacuum pump will automatically be turned off if a “Vacuum Leak” alert is presented. This will protect oil filled pumps from losing their oil and potentially damaging the pump in the event of a major vacuum leak. **The factory default setting for vacuum pump protection is ON, and it is highly recommended that it remains in the ON setting.** If vacuum pump protection is turned OFF, the pump will continue to run after a “Vacuum Leak” alert is presented (i.e., there is no protection for the pump in the event of a major vacuum leak).

Maintenance		
<b>Vacuum Pump Settings:</b>		
Operating hours since oil change:	0	Reset
Set hours between oil change:	1000	
Date of last oil change:	Unknown	
Total operating hrs for this pump:	0	Reset
<b>Refrigeration System Settings:</b>		
Total operation hrs:	0	
Back		

Maintenance			
Total operating hrs for this pump:	0	<input type="button" value="Reset"/>	
<b>Refrigeration System Settings:</b>			
Total operation hrs:	0		
Date of last service/cleaning:	Unknown		
<b>Freeze Dryer Line Voltage Offset:</b>	0	<input type="button" value="Low"/>	<input type="button" value="High"/> 0
Vacuum Pump Protection	<input type="button" value="ON"/>		
<input type="button" value="Back"/>			

7. **Calibration** – Some sensors in the Freeze Dryer can be calibrated. This process should be done by a qualified technician or metrologist with reference sensors that are known with certainty. An external reference sensor must be placed at the same measurement point (as close as physically possible) as the sensor being calibrated. The Collector temperature sensor has its own reference thermocouple (type T) built into the sensor. The thermocouple is a brown wire that is coiled inside the housing of the Freeze Dryer and can be accessed by removing the lower stainless steel front panel. A thermocouple meter can be used to read the thermocouple value as a reference value.

Sensor Calibration			
Sensor Name	Current Reading (uncorrected)	Offset	Last Cal. Date
Collector	-50.2°C	0.0	09-02-2021
Vacuum	0.033 mbar	0.000	09-02-2021
<input type="button" value="Back"/>			

- **Current Reading (uncorrected)** – This gives the raw sensor reading with no offset applied to the reading.
- **Offset** – This is the value that will be added to the Current Reading (uncorrected) to give the proper adjusted reading that matches the reference sensor being used for calibration. The adjusted reading (uncorrected + Offset) is the value that will be presented on all screens outside of the Sensor Calibration screen. Pressing the Offset field of the desired sensor will bring up a dialog box for entering the offset value for the selected sensor.

## Chapter 4: Lyo-Works Operating System

CALIBRATION

---

Offset:

Temperature Offset range is +/-5 °C

CANCEL
CALIBRATE

- **Calibrate** - Pressing this button will save the entered offset value. Temperature sensor offset values can range from -5 to +5° C. Vacuum Sensor offset values can range from -0.020 to +0.020 mbar.
8. **Display** – This screen contains settings for controlling various functions of the touch screen display.

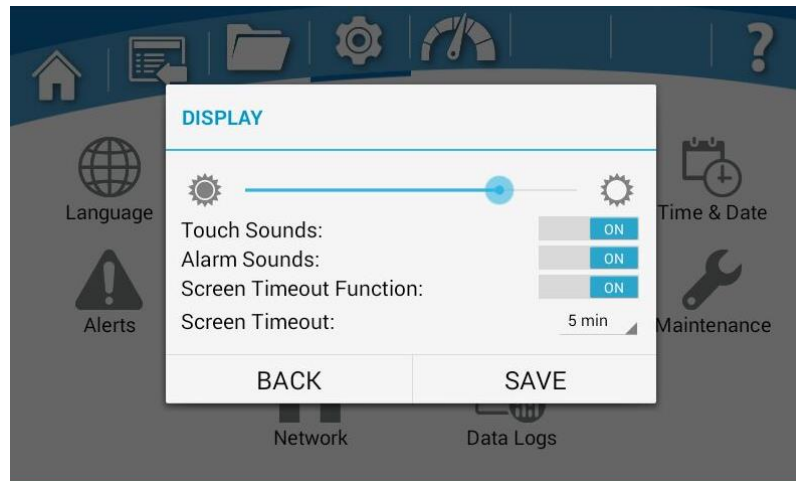

- **Brightness Slider** – Moving the slider to the right will increase the brightness level, moving to the left will decrease the brightness level of the display.
- **Touch Sounds** – With Touch Sounds turned ON, there will be an audible sound each time the display is touched. Pressing the Touch Sounds button will toggle between ON & OFF.
- **Alarm Sounds** – With Alarm Sounds turned ON, there will be an audible sound each time an alert message is displayed.
- **Screen Timeout Function** – If this function is turned ON, the screen will go into low power mode (sleep) when no screen touches have been detected for the allotted set time (Screen Timeout). Pressing the Screen Timeout Function button will toggle between ON & OFF.
- **Screen Timeout** – This value can be set to 5, 10, 15, 30 min, 1, 2, or 3 hours.

9. **Network** – If the DHCP Enabled button is turned ON, and an Ethernet cable is connecting the Freeze Dryer to an active network, then the IP Address, Subnet Mask, and Default Gateway fields will be populated automatically. If the DHCP Enabled button is turned OFF, the IP Address, Subnet Mask, and Default Gateway fields can then be manually entered to establish a network connection. If you do not know the proper information to enter into each of the Network fields, consult your IT personnel.

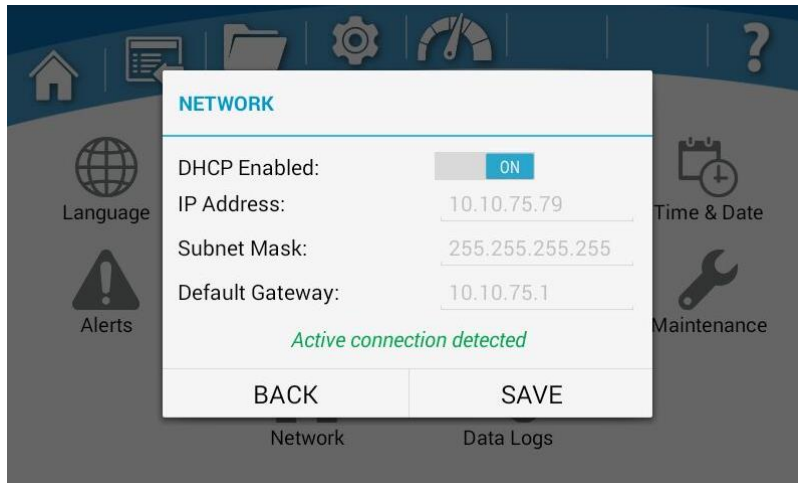

10. **Data Logs** – Allows user to make changes to default settings for Data Acquisition Rate, Log File Deletion and Data Export Options.

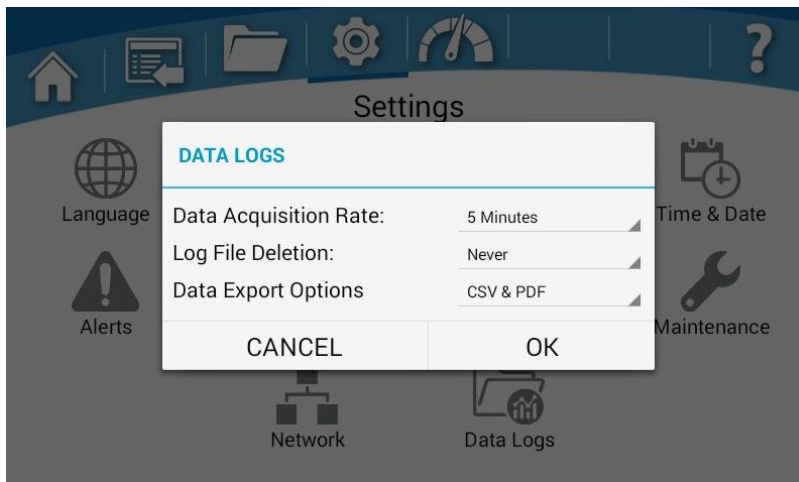

## Sensors Screen

This screen contains a list of all sensors currently installed on the Freeze Dryer and any attached accessory. The screen can be scrolled up and down if the list is too long to be viewed on a single page. The Sensors screen is for viewing only (there are no selectable fields on this screen).

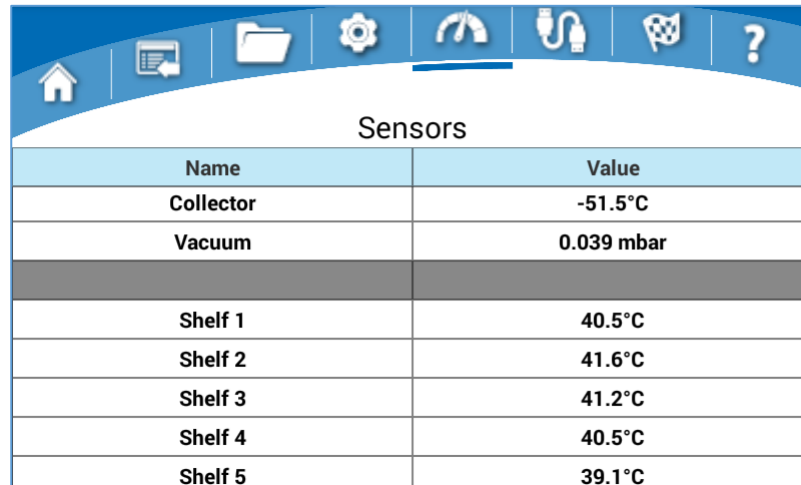

Sensors	
Name	Value
Collector	-51.5°C
Vacuum	0.039 mbar
Shelf 1	40.5°C
Shelf 2	41.6°C
Shelf 3	41.2°C
Shelf 4	40.5°C
Shelf 5	39.1°C

## Drying Accessory Screen

If an electrically controlled Drying Accessory is NOT connected to the Freeze Dryer (via the communication cable), the Drying Accessory icon will NOT appear in the main menu bar. If one of these accessories has been properly connected to the Freeze Dryer, the Drying Accessory icon will appear in the main menu bar and you will be able to control and monitor the Drying Accessory from this screen.

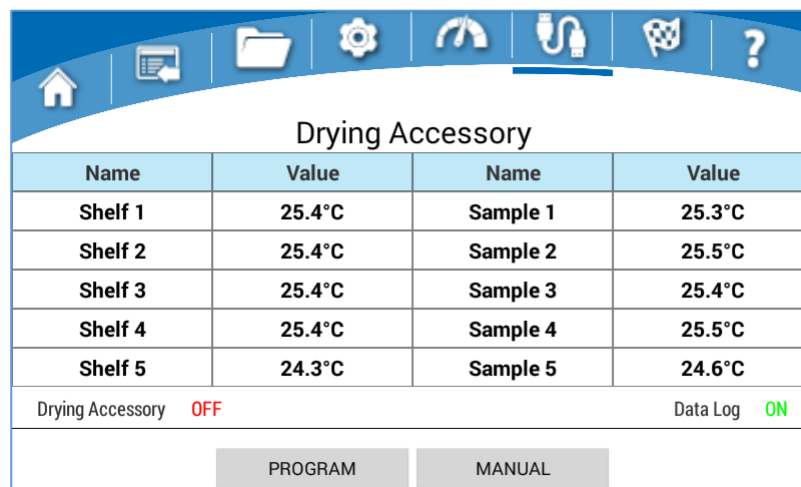

Drying Accessory			
Name	Value	Name	Value
Shelf 1	25.4°C	Sample 1	25.3°C
Shelf 2	25.4°C	Sample 2	25.5°C
Shelf 3	25.4°C	Sample 3	25.4°C
Shelf 4	25.4°C	Sample 4	25.5°C
Shelf 5	24.3°C	Sample 5	24.6°C
Drying Accessory <b>OFF</b>		Data Log <b>ON</b>	
PROGRAM		MANUAL	

**Drying Accessory Sensor Table** – The middle section of the screen displays a list of all the sensors that are available for the connected Drying Accessory. Sensors that are disconnected will have three dashes (---) for their value.

**Drying Accessory Status Box** – The status box is located directly below the sensor table. The text on the left side will indicate the current operation mode of the Drying Accessory (OFF, Manual, or Program). When in Manual mode, the word “Manual” and the current Shelf Temp Set Point value will be displayed in this location. If a program is running the program name, Step #, and Time Remaining (TR) in the current Step will be displayed in this location. The right side of the status box will indicate if Data Logging is currently ON or OFF.

- **PROGRAM** – Pressing this button will take you to the Programs screen, where you can create a new program, or start, edit, view, export or delete a saved program.
- **MANUAL** – Use this button to enter a Shelf Set Point Temp and/or start the Drying Accessory in manual mode.

## End Point Detection Screen

If the communication cable is NOT connected or if NONE of the vacuum sensors are connected to the End Point Detection Enclosure, the End Point Detection icon (checkered flag) will NOT appear in the menu bar. If the End-Zone end point detection accessory is properly connected to the Freeze Dryer, this screen will be used to control the End Point Detection settings for up to five individual freeze dry flasks.

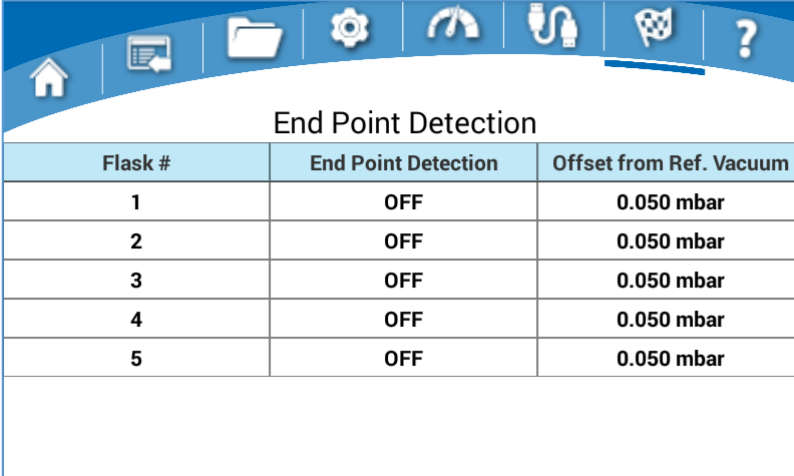

The screenshot shows a mobile application interface for 'End Point Detection'. At the top is a blue navigation bar with icons for Home, Messages, Files, Settings, a checkered flag (End Point Detection), a plug, a network icon, and a question mark. Below the bar is a table with three columns: 'Flask #', 'End Point Detection', and 'Offset from Ref. Vacuum'. The table contains five rows of data, all with 'OFF' status and '0.050 mbar' offset.

Flask #	End Point Detection	Offset from Ref. Vacuum
1	OFF	0.050 mbar
2	OFF	0.050 mbar
3	OFF	0.050 mbar
4	OFF	0.050 mbar
5	OFF	0.050 mbar

- **End Point Detection status** – Shows the current status for each flask. The status will be one of the following: ON, OFF or COMPLETE. Touching the end point detection cell for any given flask will allow you to turn the end point detection ON/OFF. The End Point Detection status will display COMPLETE automatically when an End Point Detection alert is achieved for any given flask.
- **Offset from Ref. Vacuum** – This allows the user to determine the level of dryness at which the system will declare that the primary drying end point has been reached. The offset from Ref. Vacuum represents the difference between the Reference vacuum sensor and the individual

## Chapter 4: Lyo-Works Operating System

flask sensor. This value can be set from 0.010 to 0.050 mbar (0.010 being the most dry & 0.050 being the least dry).

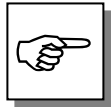

END POINT DETECTION INDICATES THE END OF THE PRIMARY DRYING PHASE. SOME SAMPLES MAY REQUIRE ADDITIONAL FREEZE DRYING TIME (SECONDARY DRYING PHASE) TO ACHIEVE THE DESIRED MOISTURE CONTENT.

## Help Screen

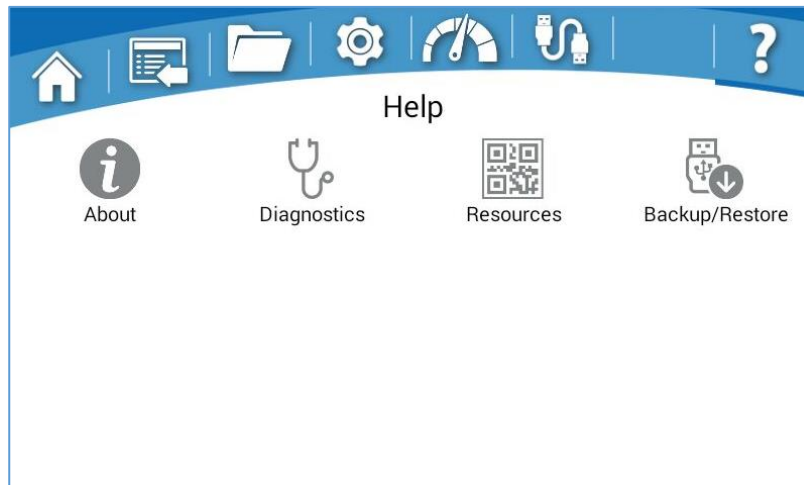

- **About** – Displays the catalog number of the Freeze Dryer and the software versions currently installed.
- **Diagnostics** – This screen will give information about the power supply to the Freeze Dryer (Voltage, Current & Frequency) and allow the user to run Manual or Auto Diagnostics on the unit.

Diagnostics	
Freeze Dryer 120 V 0.1 A 60 Hz	
COMPONENT	Test Result
▶ Run Auto Diagnostics	
▶ DEFROST VALVE RELAY	
▶ VENT VALVE	
▶ VACUUM RELAY	
▶ COMPRESSOR RELAY	
<input type="button" value="Back"/> <input type="button" value="Export USB"/> <input type="button" value="Export Email"/>	

- **Resources** – Scan QR codes with smart phone to take you to specific pages of the Labconco website (Labconco.com).

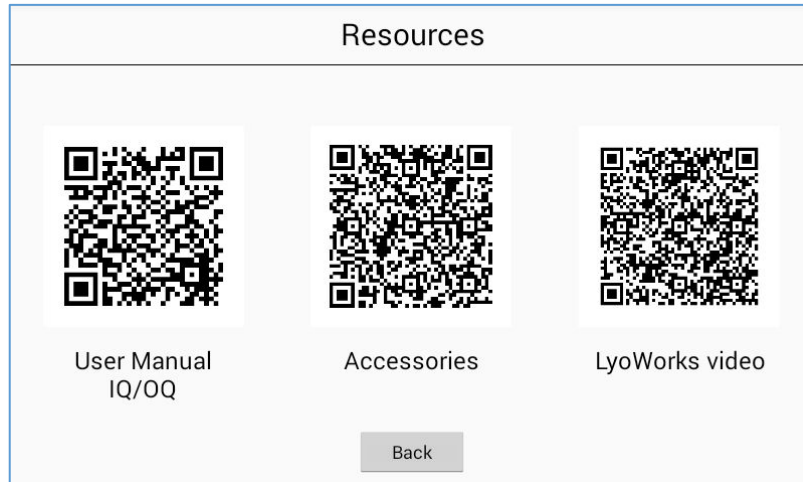

- **Backup/Restore** – Log files & User Programs can be exported to a USB flash drive. Only user program can be imported to the Freeze Dryer from a USB flash drive.

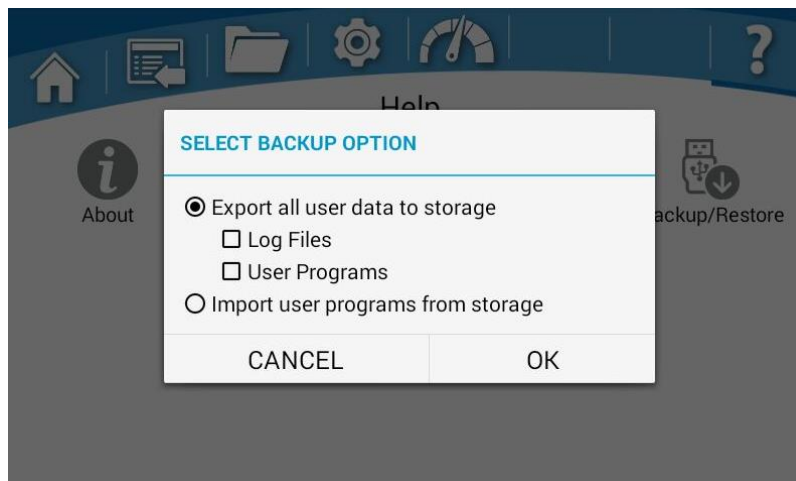



---

# CHAPTER 5

## USING YOUR FREEZE DRYER

### Operation Checklist

The following checklist should be followed prior to each use of your Freeze Dryer:

1. Remove the accessory drying chamber or manifold from the collector chamber lid and using a soft, lint-free cloth or paper towel, wipe the port gasket(s) and sealing surfaces of the drying chamber/manifold and collector chamber lid to remove any dirt or contaminants that could cause a vacuum leak.
2. Remove baffle (if equipped) and wipe with a soft cloth or paper towel to remove any remaining moisture.
3. Ensure that the collector chamber and drain line are free of water. Place the drain hose in a suitable container to collect the condensate from the collector chamber. Insert the quick connect drain fitting into the quick connect drain coupling located on the left hand side of the Freeze Dryer. **Note: Freeze Dryer (Collector or Vacuum) will not start if moisture is detected in the drain line.**
4. After completely draining the system, disconnect the quick connect drain fitting from the quick connect drain coupling.

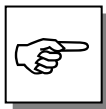

DISCONNECT THE QUICK CONNECT DRAIN FITTING BEFORE STARTING THE VACUUM PUMP. FAILURE TO REMOVE THE FITTING WILL RESULT IN A LARGE VACUUM LEAK.

5. Wipe the interior of the collector chamber with a soft cloth or paper towel to remove any remaining moisture.
6. Reinstall baffle (if equipped) in collector chamber.
7. Reinstall the drying chamber or manifold on the collector chamber lid. **Note: Vacuum grease is NOT required on the drying or collector chamber lid gasket to obtain a proper vacuum seal.**
8. Check that each sample valve is closed or in the “vent” position.
9. Start COLLECTOR and allow the refrigeration system to reach its specified operating temperature (-50°C, -84°C, or -105°C depending on model)
10. Start VACUUM when collector temperature is -40°C or colder.

11. Attach a pre-frozen sample to sample valve on drying chamber or manifold.  
Note: If using a Clear Chamber, Tray Dryer or Heated Product Shelves, the vacuum chamber must be fully vented (to atmospheric pressure) in order to remove acrylic chamber or open door before loading sample into the drying chamber.

## Vacuum Pump Ballast Setting

Most vacuum pumps are equipped with a gas ballast mechanism. The freeze dry process requires high vacuum. Therefore, it is recommended that the gas ballast be closed during the operation of the Freeze Dryer. If the gas ballast is left open for extended periods of operation, the oil can be pumped out the exhaust, causing the pump to fail.

## Operating the Freeze Dryer

### Auto start-up

1. Go to Home screen
2. Press AUTO, then press START
  - COLLECTOR will start immediately
  - VACUUM will start when collector temperature reaches -40°C

### Manual start-up

1. Go to Home screen
2. Press COLLECTOR, then press START
3. When COLLECTOR temperature reaches -40°C (or colder)
  - Press VACUUM, then press START

## Setting the Operating Vacuum Level

To change the Vacuum Set Point

1. Go to Home screen
2. Press VACUUM,
  - enter new Vacuum Set Point value
  - press APPLY (or START if vacuum pump is not already running)

The vacuum level may be set by the user to optimize the freeze dry process. Normally, the sublimation rate will increase as the pressure increases in the Freeze Dryer. A good starting place is to set the vacuum so its level is equivalent to about 10°C colder than the eutectic or collapse temperature of the sample. The reference table below shows the relationship between ice temperature and vapor pressure.

## Chapter 5: Using Your Freeze Dryer

### Vapor pressure above ice

Temp. (°C)	Pressure (mbar)	Temp. (°C)	Pressure (mbar)	Temp. (°C)	Pressure (mbar)	Temp. (°C)	Pressure (mbar)	Temp. (°C)	Pressure (mbar)
0	6.11	-11	2.37	-21	0.94	-31	0.34	-50	0.039
-1	5.63	-12	2.17	-22	0.85	-32	0.31	-60	0.011
-2	5.18	-13	1.98	-23	0.77	-33	0.28	-70	0.003
-3	4.76	-14	1.81	-24	0.70	-34	0.25	-80	0.001
-4	4.37	-15	1.65	-25	0.63	-35	0.22		
-5	4.02	-16	1.50	-26	0.57	-36	0.20		
-6	3.69	-17	1.37	-27	0.52	-37	0.18		
-7	3.38	-18	1.25	-28	0.47	-38	0.16		
-8	3.10	-19	1.13	-29	0.42	-39	0.14		
-9	2.84	-20	1.03	-30	0.38	-40	0.13		

Adjustments to the vacuum level must be made for various freeze drying conditions. Factors that must be considered are whether the sample is freeze dried on heated shelves or in glassware attached to manifold valves, the volatility of the sample itself, the size of the sample and the heat energy supplied to the sample. Some guidelines for setting the vacuum level are shown below. Exact protocols must be determined by the user for the specific samples that are being freeze dried.

Material	Solidification/Eutectic Temperature	Pre-Freeze Temperatures	Vacuum Set Point
Bacteria, Virus	≤ -40°C	≤ -50°C	≤ 0.04 mbar
Milk	-5 to -13	-15 to -23	1.65 to 0.77
Fungi	≤ -40	≤ -50	≤ 0.04
Vegetable Tissue	-25 to -50	-35 to -60	0.22 to 0.01
Human Tissue	-30 to -40	-40 to -50	0.12 to 0.04
Blood Plasma	-10 to -25	-20 to -35	1.03 to 0.22
Vaccine	-30 to -40	-40 to -50	0.12 to 0.04

When the vacuum control is set to operate at less vacuum (higher pressure), the ice holding capacity of the collector may be decreased. This can be improved by installing a baffle in the collector chamber. See *Appendix A Freeze Dry Components* for the baffle part number. See *Chapter 3: Baffle Installation* for proper positioning of the baffle in the collector chamber.

## Pre-Freezing Samples

Appropriate containers for freeze drying include ampules, serum bottles, and wide mouth freeze drying flasks. Shell freezing of samples is recommended for wide mouth freeze drying flasks. Smaller samples in ampules and serum bottles may be frozen in a freezer or in the center of the collector chamber. The sample container size should always be at least two to three times the sample size (i.e., 40 ml samples should be prepared in 80 ml containers or larger). The temperature required for pre-freezing is dependent on the characteristics of the sample. Pre-

freezing temperature is typically at least 10° to 20°C below the eutectic or collapse temperature of the sample.

## Adding Sample

The following procedure should be followed when using chambers or manifolds with sample valves in the freeze dry process:

1. Connect a pre-frozen sample to a sample valve on the drying chamber or manifold using an adapter. Turn the plastic valve knob to the “VACUUM” position to open the valve, which connects the attached sample to system vacuum. The bevel on the knob should be positioned toward the sample port to apply vacuum to the sample.

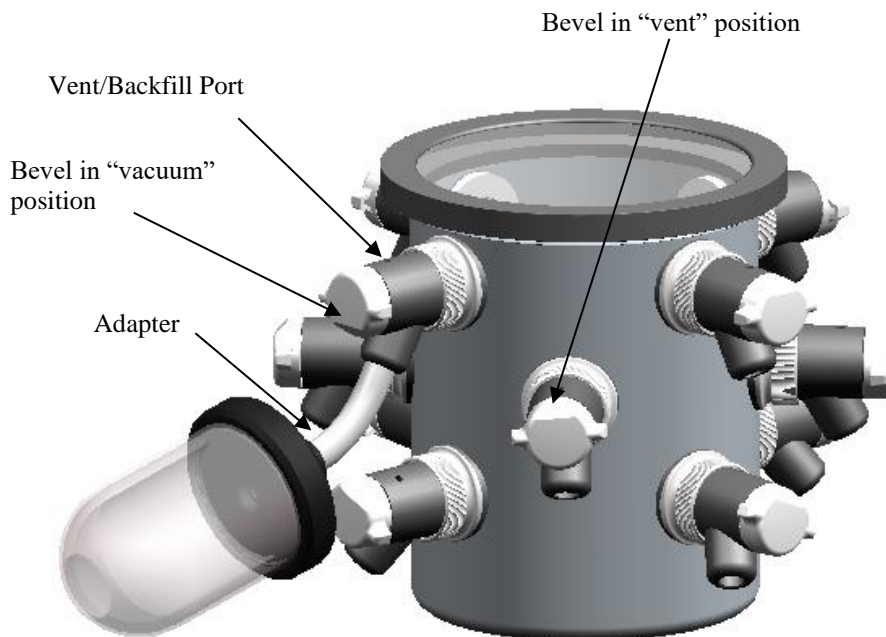

2. Before adding another sample, allow system vacuum to return to 0.133 mbar or lower. Any combination of valves and sample sizes may be utilized at one time provided that the system vacuum and collector temperature remain sufficiently low to prevent melting of the frozen sample.
3. When all the frost has disappeared from the outer surface of the sample container and no cold spots can be detected by handling the container, the sample is nearly dry. To be certain of low final moisture content, dry the sample for several hours past this point.
4. To remove a container after drying is complete, turn the plastic knob on the valve to the “VENT” position, which closes the valve and vents the container. Should backfilling with an inert gas be required, connect the gas supply line to the vent port on the valve before turning the plastic knob on the valve to vent position. The sample container may now be removed. In the vent position the bevel on the valve knob should point away from the sample port.

## Chapter 5: Using Your Freeze Dryer

---

5. Ampules may be flame sealed while connected to a valve by using a sealing torch. Care must be taken not to burn the valve. An insulation material placed between the valve and the torch is recommended.

### Starting a Program (for optional drying accessories)

If one of the electronically controlled accessory drying chambers, suitable for your Freeze Dryer, has been properly installed, you will be able to run a program.



BEFORE STARTING A PROGRAM YOU SHOULD ALWAYS ENSURE THAT THE COLLECTOR IS “ON” AND HAS COOLED TO -40°C OR BELOW.

1. Go to the Programs screen. You can access the Programs screen in two different ways, both lead to the same location.
  - a. Directly access the Programs screen by selecting the Programs icon from the main menu bar at the top of the display.
  - b. Go to the Drying Accessory screen, then select the PROGRAM button at the bottom of the screen.
2. Select a program from the saved programs list, or create a new program.
3. With the desired program selected from the list, press the START button.

### Shut Down

At the end of a run or when a sufficient amount of condensate accumulates on the collector coil to obstruct the flow of vapor to the collector chamber, the Freeze Dryer should be defrosted. Go to Home screen, press VACUUM, then STOP to turn the vacuum pump OFF. Then release system vacuum by turning the plastic knob on a valve (that has no sample attached) to the open position or opening the vent valve on Tray Dryer or Clear Chamber. Press COLLECTOR, then STOP to turn the refrigeration system OFF.

### Defrosting

The following procedure should be followed when defrosting the collector coil:

1. The hot gas defrost function can be used to speed up the defrosting process. Defrost can be activated as follows: Go to Home screen, press COLLECTOR button, press Defrost Options, then press START.
2. To turn off Defrost: Go to Home screen, press DEFROST button, press STOP. The defrost function will turn off automatically if the collector temperature reaches +60°C or if defrost has been running for 2 hours.
3. If rapid defrost is desired, pour warm water over the collector coil. **Do not** allow the liquid to enter the vacuum port on the upper rear wall of the chamber.
4. Place the drain hose in a suitable container to collect the condensate from the collector chamber. Insert the quick connect drain fitting into the quick connect drain coupling located on the left hand side of the unit.
5. Flush the collector chamber with water and wipe chamber dry.

6. Disconnect the quick connect drain fitting from the quick connect drain coupling.

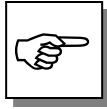

**DISCONNECT THE QUICK CONNECT DRAIN FITTING BEFORE STARTING THE VACUUM PUMP. FAILURE TO REMOVE THE FITTING WILL RESULT IN A LARGE VACUUM LEAK.**



**Utilization of acid requires immediate cleaning and neutralization after defrost or physical damage to the collector chamber and collector coil will result.**

**Do not attempt to chip ice from the collector coil as damage may occur to the coil.**

**Never attempt to start the vacuum pump when there is liquid in the collector chamber. This could result in damage to the vacuum pump.**

## Alerts

A number of events may occur during a lyophilization procedure that will cause an alert to be displayed on the Freeze Dryer touch screen. An audible alarm (beeper) will also be sounded that will automatically be muted after one minute.

The specific alert type can be identified by observing the message box on the display. The alert message box and audible alarm can be dismissed by pressing the “Back” button on the alert message box. The following conditions will initiate an alert.

### Power Fail

If a power failure occurs during a Freeze Dry process, the vacuum control valve will allow air to bleed into the Freeze Dryer System. If the failure is of a short duration and the collector does not warm up above  $-30^{\circ}\text{C}$ , when power is restored the Freeze Dryer will restart and resume operation of the refrigeration and vacuum systems. If the power failure lasts for a longer duration and the collector warms above safe limits, when the power is restored, the Freeze Dryer will not automatically restart. This prevents melted sample from being drawn into the collector and prevents liquid from being drawn into the vacuum pump.

When power is restored, the POWER FAIL alert message will be displayed on the touch screen and the audible alarm will sound.

### Line Voltage Range

If the voltage supplied to the Freeze Dryer varies beyond allowable limits, the LINE VOLTAGE RANGE alert will be activated. The high and low alarm points are preset at the factory to correspond to the normal allowable voltage variations based on the nominal voltage specified for the freeze dryer. Some models may be

---

## Chapter 5: Using Your Freeze Dryer

---

operated outside the normal voltage limits (see *Appendix C*). If necessary, the high and low LINE VOLTAGE OFFSETS may be adjusted from the Settings / Maintenance screen.

### Collector Temp

After the collector temperature has cooled to below  $-40^{\circ}\text{C}$ , an alert will be activated if the collector temperature rises above  $-40^{\circ}\text{C}$  for more than 5 minutes.

### Collector Moisture

If there is liquid in the collector chamber and either the COLLECTOR or VACUUM start button is pressed, neither function will start and an alert will be activated. This feature prevents the inadvertent start of the vacuum pump when liquid is in the collector and thereby can extend the life of the vacuum pump. A few drops of liquid may remain in the drain hose after draining. When the vacuum pump is started these drops may be sucked into the collector chamber. This is normal.

### Service Vacuum Pump

The vacuum pump normally plugs into the vacuum pump electrical receptacle on the back of the Freeze Dryer. When the Freeze Dryer has accumulated a total of 1000 operating hours, an alert will be activated. It may be necessary to service the vacuum pump more frequently than every 1000 hours depending on the operation of the Freeze Dryer. **The pump oil should be regularly monitored to verify that it is clean.** The “Set hours between oil change” can be reprogrammed from the Settings / Maintenance screen for any value from 0 to 9999 hours.

### Vacuum Leak

If the vacuum level in the freeze dryer has not reached at least 5 mbar within 30 minutes of starting the vacuum, an alert will be activated and the vacuum pump will be turned off (if it is plugged into the Freeze Dryer vacuum pump outlet).

### Vacuum Set Point

If the system is unable to achieve the vacuum set point (during Manual or Program mode), an alert will be activated. This alert will be activated if the vacuum level is not within 0.500 mbar of the vacuum set point in 20 minutes.

### Status Email Messages

If this option has been turned on, the selected email addresses will receive STATUS alert messages containing the current operating parameters of the Freeze Dryer. Status alert messages will not be displayed on the touch screen. The Freeze Dryer can be configured to send email status alert messages from the Settings / Alerts / Select Alerts screen.

### **End Point Detection (optional accessory)**

An alert will be activated when the primary drying phase end point has been detected for any of the active flask sensors connected to the End-Zone end point detection accessory.

### **Shelf Temp Variation (optional accessory)**

If a Tray Dryer or Heated Product Shelves accessory is connected to the Freeze Dryer this alert will be activated if the shelf temperature varies more than  $\pm 3^{\circ}\text{C}$  from the Shelf Temp Set Point.

### **Shelf Temp Set Point (optional accessory)**

If a Tray Dryer or Heated Product Shelves accessory is connected to the Freeze Dryer this alert will be activated if the shelf temperature stabilized without reaching the Shelf Temp Set Point.

### **Power Fail (optional accessory)**

If a Tray Dryer or Heated Product Shelves accessory is connected to the Freeze Dryer this alert will be activated if a power failure occurs to the accessory.

### **Program Complete (optional accessory)**

If a Tray Dryer or Heated Product Shelves accessory is connected to the Freeze Dryer this alert will be activated when the last step of a running program has been completed.

## **Export a Data Log File**

Data Log Files can be copied (exported) to a USB flash drive via the USB port on the left side of the Freeze Dryer. The file will be exported as a “comma separated values” file (.csv file extension), which can be easily opened with a spreadsheet application program for data analysis and graphing. To export a file:

1. Insert USB flash drive into the Freeze Dryer USB port
2. Go to Data Logging screen
3. Select the file that you want to export by pressing the Data Log File name
4. Press the Export button

## **Downloading Data Log Files via Ethernet**

Data log files that are stored in the Freeze Dryer can be downloaded via an Ethernet connection. In order for this to be possible, a working Ethernet connection must first be established. The following steps must be completed:

1. An Ethernet cable must be connected to the Ethernet port on the back of the Freeze Dryer and to a Local Area Network (LAN) with working internet service.
2. The proper settings must be entered into the Settings>Network screen to establish a valid network connection (see description of Network screen in Chapter 4).



## Chapter 5: Using Your Freeze Dryer

3. Write down the “IP Address” shown on the Settings>Network screen of the Freeze Dryer (this number will be used in Step 5)
4. Open an internet browser of your choice from a computer that is connected to your LAN.
5. Type the following into the address bar at the top of the browser screen: **http://“IP Address”:8080** where “IP Address” represents the number written down from the Settings>Network screen in Step 3 (example = **http://10.10.9.117:8080**).

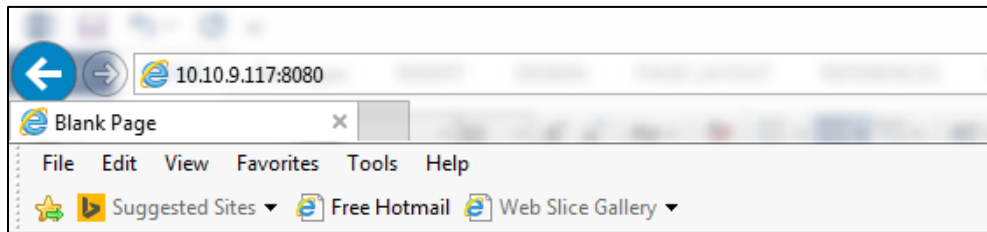

6. The following webpage will appear with a list of all the Data Log files that are stored on the Freeze Dryer.

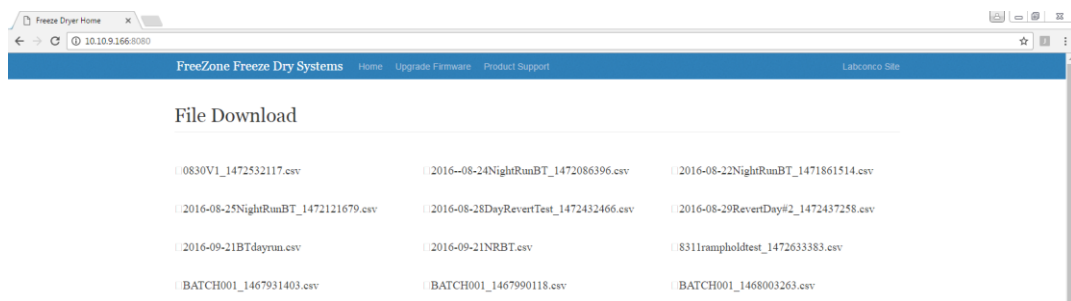

7. Single click on a file name from the list to download the file.
8. Single click on the downloaded file to open the file in Excel.

## Copy a Program

If you wish to duplicate a program or quickly create a program that is similar to an existing program, you can use the copy program function. The new program file created by the copy function will be stored on the Freeze Dryer. To copy a program:

1. Go to Programs screen
2. Select a program from the list by pressing the program name
3. Press the COPY button
4. Edit program name if desired (the default program name will be “*program name\_copy*”)

---

# CHAPTER 6

# MAINTAINING YOUR FREEZE DRYER

## Service Safety Precautions



- Always ensure that only authorized technicians service the refrigeration, vacuum and electrical systems.
- If performing any electrical maintenance, always disconnect the power at the main disconnect.
- If the refrigeration system must be operated with access panels removed (for diagnostic purposes only), stay clear of moving fan blade.
- Always practice team lifting when moving heavy equipment.
- After servicing, verify that all access panels or covers are in place before resuming normal operation of the equipment.

## Routine Maintenance Schedule

Under normal operation, the Freeze Dryer requires little maintenance. The following maintenance schedule is recommended:

### As needed:

1. Clean up all spills; remove liquids from the chamber.
2. Clean lid and gasket using soft cloth, sponge or chamois and a mild, non-abrasive soap or detergent.
3. Check oil level of the vacuum pump. It should be between MIN and MAX. If the oil level is less than an inch (25.4 mm) above MIN, add oil to proper level.
4. If oil shows cloudiness, particles or discoloration, drain the pump and replace with fresh oil.
5. **Utilization of acids requires immediate cleaning and neutralization after a run or physical damage to the collector chamber and collector coil will result.**

## Chapter 6: Maintaining Your Freeze Dryer

---

6. Check the collector chamber for condensed or frozen solvents and dispose of appropriately. Completely empty the collector chamber before the next run or before attempting to start the vacuum pump.
7. If sample valves leak or stems become difficult to turn, pull the stem out of the rubber valve body and apply a thin coat of vacuum grease to the stem. Reinsert the stem into the valve body.

### **Monthly:**

1. The rubber components on the Freeze Dryer may eventually deteriorate and require replacement. The effective life of rubber parts depends upon both their usage and the surrounding environment. Check all rubber hoses and gaskets and replace any that show signs of hardening, permanent set or deterioration.
2. Using a soft cloth, sponge or chamois and a mild, non-abrasive soap or detergent, clean the acrylic chamber lid.
3. Using a soft cloth, sponge, or chamois and a mild, non-abrasive soap or detergent, clean the exterior surfaces of the Freeze Dryer. Liquid spray cleaners and polishes may be used on the exterior surfaces. Do not use solvents to remove stains from the exterior surfaces as they may damage the finish.

### **Annually:**

1. Every 12 months, or more often if the Freeze Dryer is operated in a dusty environment, the refrigeration system condenser should be cleaned. Using a vacuum cleaner with brush attachment, clean the condenser to ensure proper airflow for peak performance.

---

# CHAPTER 7

## TROUBLESHOOTING

Refer to the following if your Freeze Dryer fails to operate properly. If the suggested corrective actions do not solve your problem, contact Labconco for additional assistance.

Labconco Freeze Dry Systems that are clean, dry and without samples attached should reach a vacuum of 0.133 mbar within 10 minutes and should achieve an ultimate vacuum of 0.040 mbar within 18 hours when the refrigeration is operating. If the Freeze Dryer does not obtain a satisfactory vacuum, perform the following maintenance tests.

### I. Vacuum Pump

First make sure that the vacuum pump operates. If it fails to operate, check the electrical connections of the Freeze Dryer to the power source and then check the electrical connection of the vacuum pump to the Freeze Dryer. If the vacuum pump has a power switch, make sure that it is turned on. **Note: If the vacuum pump is plugged directly into a wall outlet for troubleshooting purposes, the vacuum START button must be initiated on the display screen. If the vacuum START button is not initiated the vacuum vent valve will remain open and the vacuum reading will remain on HIGH.** If the vacuum is not adequate when the vacuum pump is operating, proceed with the following steps:

1. Check the oil and ensure it is clear and clean. If the oil looks cloudy or has any particulates, replace the pump oil. Sometimes it may be necessary to flush the pump with clean oil several times. To flush the pump, run the pump 5 to 10 minutes to allow the oil to warm up. Drain the oil and refill with clean oil. Repeat as necessary.
2. Check the oil level in the pump. Ensure it is filled to the correct level.
3. Check vacuum hose connections from the pump to the Freeze Dryer and try running the unit.

## Chapter 7: Troubleshooting

---

If vacuum problems continue, consider obtaining a second vacuum gauge capable of reading a vacuum of 0.010 mbar. It is often useful in determining if the vacuum pump is operating properly and the vacuum sensor reading is accurate.

4. Isolate the pump by disconnecting the vacuum hose from the Freeze Dryer. Deadhead the pump by inserting the vacuum sensor from a secondary vacuum gauge into the end of the vacuum hose and observe the vacuum reading obtained. Confirm that the pump is capable of achieving an ultimate vacuum less than 0.010 mbar or approximately 10 microns. If an inadequate vacuum reading is obtained, the pump has most likely failed and may need to be replaced or rebuilt.

## II. Gaskets, Tubing, Connections, Sample Valves

1. Check all sample valves on the drying chamber/manifold and ensure all valves are closed or in the vent position. Check to ensure all fittings are tight and sealed properly against the chamber. Inspect valves for cracks or cuts.
2. Inspect gasket(s) for cracks or defects. Ensure the gasket is clean. Apply a thin coat of vacuum grease to the gasket. Keep in mind too much vacuum grease can actually cause leaks.
3. Check the drain line and ensure that the quick connect drain fitting is disconnected from the quick connect drain coupling (on the left side of the Freeze Dryer).
4. Check all rubber vacuum tubing for signs of deterioration or cracking.
5. Check all connections and make sure they are secure and leak tight.
6. When checking the sample valves, pull as much vacuum as possible. If a vacuum indication is displayed, wiggle or rotate the valves and watch the gauge for any fluctuations. Fluctuations can indicate a potential vacuum leak. If the valve seems to be in good condition, remove the valve and apply a thin coat of vacuum grease to the stem and the outside sealing surface of the valve body, and reinstall the valve. **DO NOT APPLY VACUUM GREASE TO THE SAMPLE VALVE GASKETS, WHICH SEAL TO THE WALL OF THE DRYING CHAMBER.** If the valve still seems to be the source of the problem, remove the valve and stopper the hole with a rubber stopper. Continue checking the other valves.
7. Make sure that the sample valve bulkhead nuts are tight. Either tighten by hand or use the wrench supplied with chambers. To use the wrench, first remove the knob and stem assembly and also the valve body. The pins on the wrench fit into the round holes of the nut. The nut should be snug but avoid over tightening. Replace the valve body and knob and stem assembly.

The illustrations below show how the sample valve installs on a chamber and a manifold.

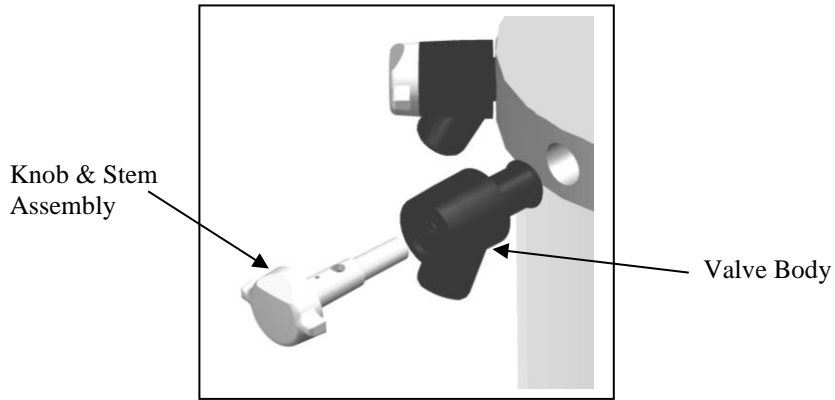

**Valve Assembly (Clear Chamber with Valves)**

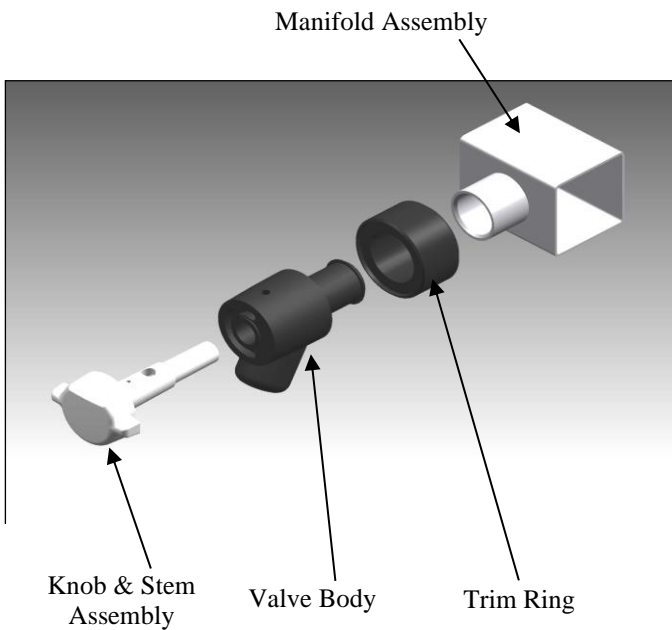

**Valve Assembly (Manifold)**

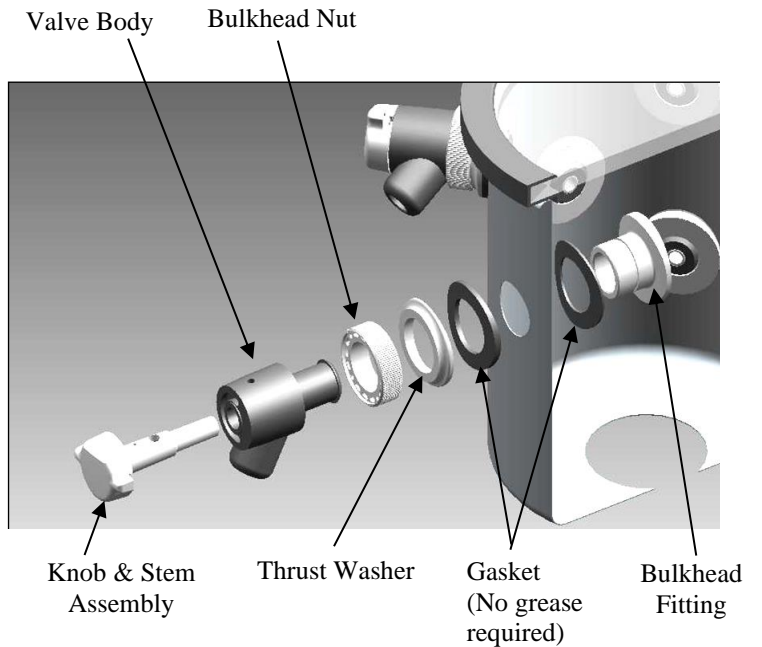

**Valve Assembly (Stainless Steel Chamber)**

## II. System Components and Collector Chamber Isolation

This test determines if the source of a leak is in the drying chamber or manifold.

1. Remove the drying chamber or manifold.
2. Leave the gasket on and turn a large freeze dry flask upside down to cover the connection port.
3. Start the Freeze Dryer and observe the vacuum indication. If the vacuum indication is good, then the problem is in the drying chamber or manifold and you should return to *Section II, Gaskets, Tubing, Connections, Sample Valves*.

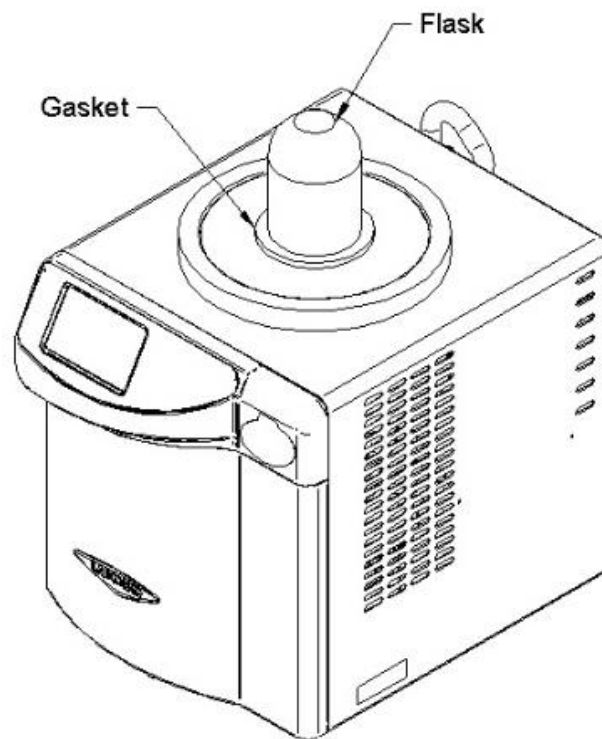

**Isolating the freeze dry system from the accessory chamber/manifold**

The following test determines if a vacuum leak is in the collector chamber.

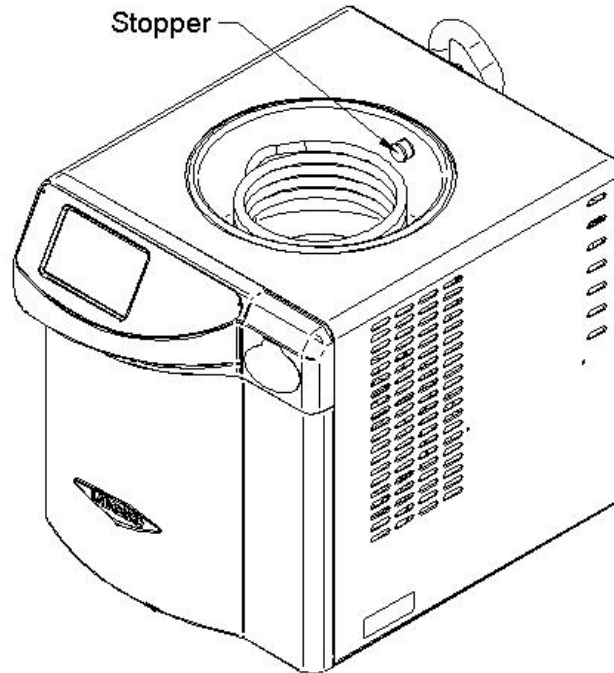

1. Insert a rubber stopper in the small hole in the rear of the collector chamber.
2. Start the Freeze Dryer and observe the vacuum indication. If the vacuum is good, the problem is in the collector chamber. If it is bad, the problem is in the plumbing connections from the collector chamber to the vacuum pump.
3. If the leak is in the plumbing connections, check all rubber parts, fittings and clamps.
4. If the leak is in the chamber, check the drain hose, hose connections and the quick connect drain coupling. The figure below shows other potential leak areas (**for 4.5L & 8L models**) where bulkhead fittings are used to seal the holes where the collector coil penetrates the bottom of the chamber.

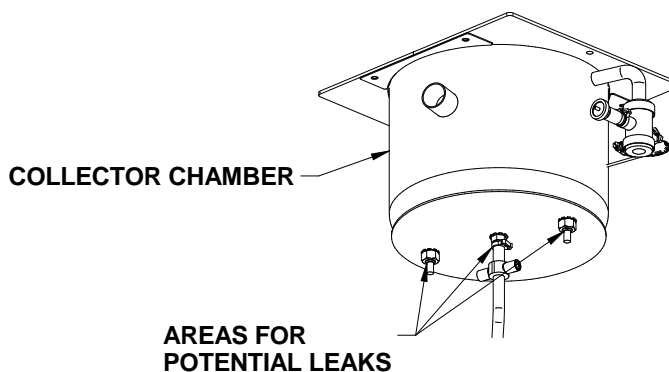



## Chapter 7: Troubleshooting

5. If a leak is observed around the bulkhead fittings, access the bottom of the chamber and remove the insulation. Tighten the appropriate fitting by placing a wrench on the fitting inside the chamber and use a second wrench to turn the nut on the bottom of the chamber. Be careful not to damage the evaporator coils or the brazed joints to the refrigeration system. Once the fitting is tightened, perform the test again. If a leak is still present at the bulkhead fittings, loosen the bulkhead fittings and apply vacuum grease to the O-rings, then reassemble and test.

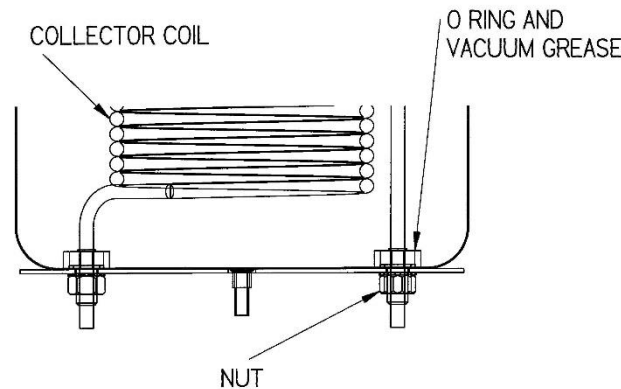

## Refrigeration Module Operation

Under a no-load condition, the FreeZone Freeze Dry Systems can achieve a collector temperature of  $-50^{\circ}\text{C}$ ,  $-84^{\circ}\text{C}$  or  $-105^{\circ}\text{C}$  (based on model designation) or lower within 30 minutes when the vacuum pump is operating, depending on ambient temperature and humidity. If the collector temperature does not reach the design temperature within 30 minutes, then the refrigeration module is not functioning properly.

If any repairs are required on the refrigeration module, contact your local laboratory supply dealer. If your laboratory supply dealer is unable to provide assistance, please call Labconco. Repairs should only be undertaken by a competent refrigeration technician or through an authorized Labconco service agency.

---

# **APPENDIX A**

# **FREEZE DRYER COMPONENTS**

The following pages list components that are available for your Freeze Dryer. The parts shown are the most common replacement parts. If other parts are required, contact Product Service.

## Appendix A: Freeze Dryer Components

### 2.5L -50C Models (70020xxxx)

### 2.5L -84C Models (71020xxxx)

Item	-50C	-84C	Part No.	Description
1	X		7395800	Lid Gasket
2	X		7395801	Lid (Acrylic)
		X	7207500	Lid Assembly, Stainless Steel (includes lid gasket 7395800)
3	X	X	7953802	Motor Fan, 115V
	X	X	7953803	Motor Fan, 230V
4	X	X	7591805	Compressor, 115V, 60Hz
	X	X	7591806	Compressor, 230V, 50Hz
	X	X	7591807	Compressor, 230V, 60Hz
5	X	X	7316600	Display Assembly
6	X	X	7337300	Gasket, Display
7	X	X	7337400	Panel, Control
8	X	X	7336900	Label, Control Panel
9	X	X	7346400	Control Panel Assembly (Complete)
10	X	X	7335200	Drain Fitting (Coupling Body)
11	X	X	7335300	Drain Fitting (Coupling Insert, 3/8 Barb)
12	X	X	7337100	Retaining Ring, Drain Fitting
13	X	X	7337000	Lanyard, Drain Fitting
14	X	X	1889406	Machine Screw, 8-32 x 3/8" long
15	X	X	7429700	Moisture Sensor
16	X	X	7373450	Vacuum Hose
17	X	X	7403800	Filter, Female Luer-Lok
18	X	X	7403700	Luer, #10-32 Male
19	X	X	7432700	Vacuum Control/Bleed Valve
20	X	X	7162300	Vacuum Sensor
21	X		7330400	Electrical Panel Assembly 115V
	X		7330401	Electrical Panel Assembly 230V
		X	7330402	Electrical Panel Assembly 115V
		X	7330403	Electrical Panel Assembly 230V
22	X	X	7515302	Temperature Sensor (Not Shown)
23	X	X	1336400	Power Cord 115V 60Hz US (Not Shown)
	X	X	1338002	Power Cord 230V 60Hz US (Not Shown)
	X	X	1332601	Power Cord 230V 60Hz Saudi (Not Shown)
	X	X	1336500	Power Cord 230V 50Hz EU (Not Shown)
	X	X	1332701	Power Cord 230V 50Hz China (Not Shown)
	X	X	1332601	Power Cord 230V 50Hz UK (Not Shown)
	X	X	1345701	Power Cord 230V 50Hz India (Not Shown)
24	X	X	7361100	Wire Harness, IOB Control (Not Shown)
25	X		7361200	Wire Harness, Power (Not Shown)
		X	7361201	Wire Harness, Power (Not Shown)
26		X	7419300	Baffle Collector
27	X	X	7205304	Drain Hose (Not Shown)

**2.5L -50C Models (70020xxxx)**  
**2.5L -84C Models (71020xxxx)**

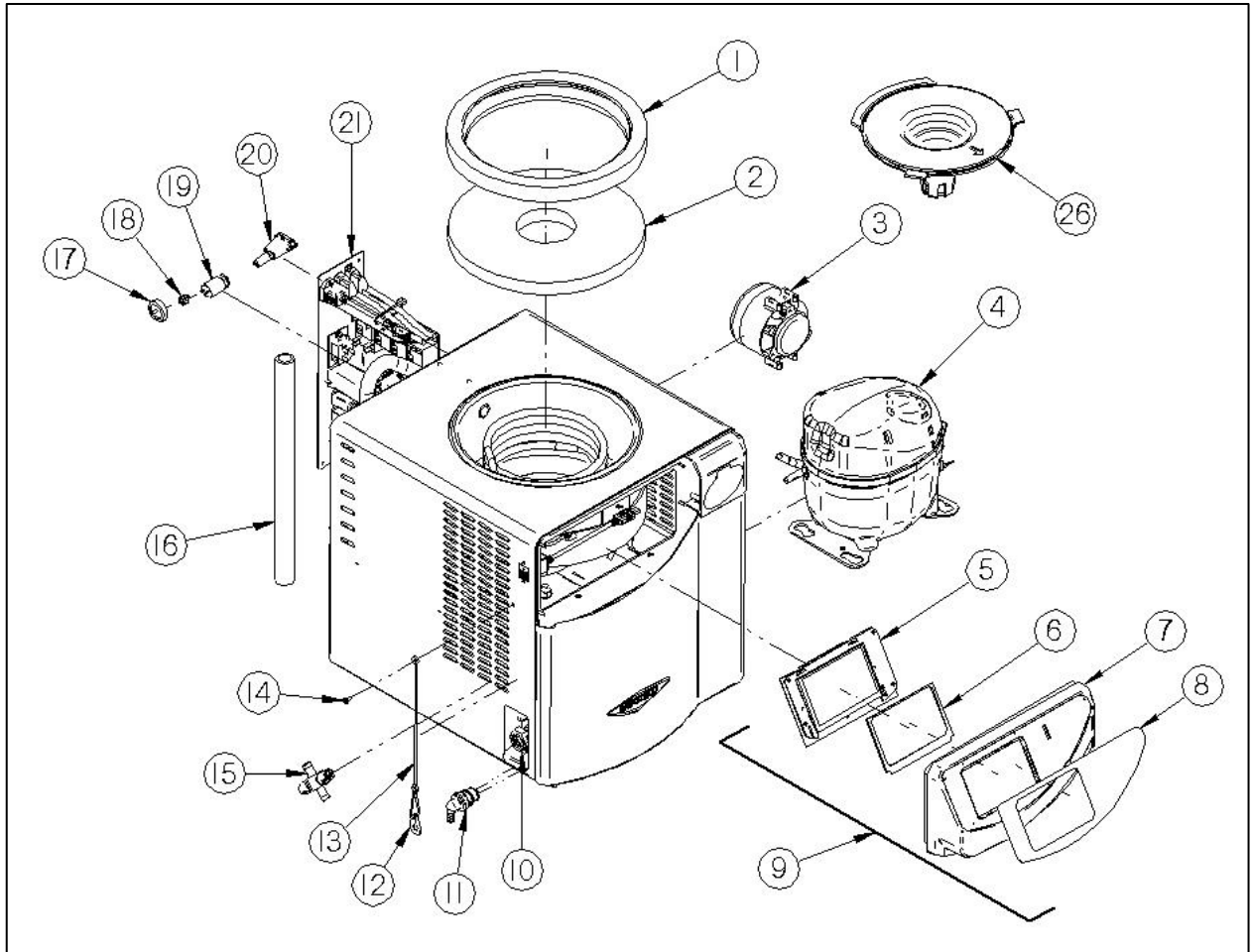

\*2.5L -50C Model Shown

## Appendix A: Freeze Dryer Components

**4.5L -50C Models (70040xxxx)**

**4.5L -84C Models (71040xxxx)**

**4.5L -105C Models (72040xxxx)**

Item	-50C	-84C	-105C	Part No.	Description
1	X			7690800	Lid Gasket
2	X			7329600	Lid (Acrylic)
		X	X	7207400	Lid Assembly, Stainless Steel (includes lid gasket 7690800)
3	X			7953802	Motor, Fan, 9 Watt, 115V
	X			7953803	Motor, Fan, 9 Watt, 230V
		X	X	7383500	Motor, Fan, 35 Watt, 115V 60Hz
		X	X	7383501	Motor, Fan, 35 Watt, 230V 60Hz
		X	X	7383502	Motor, Fan, 35 Watt, 115V 50Hz
4	X	X		7591805	Compressor, 115V, 60Hz
	X	X		7591806	Compressor, 230V, 50Hz
	X	X		7591807	Compressor, 230V, 60Hz
			X	7591900	Compressor, 115V, 60Hz
			X	7591901	Compressor, 230V, 50Hz
			X	7591902	Compressor, 230V, 60Hz
5	X	X	X	7316600	Display Assembly
6	X	X	X	7337300	Gasket, Display
7	X	X	X	7337400	Panel, Control
8	X	X	X	7336900	Label, Control Panel
9	X	X	X	7337600	Control Panel Assembly (Complete)
10	X	X	X	7335200	Drain Fitting (Coupling Body)
11	X	X	X	7335300	Drain Fitting (Coupling Insert, 3/8 Barb)
12	X	X	X	7337100	Retaining Ring, Drain Fitting
13	X	X	X	7337000	Lanyard, Drain Fitting
14	X	X	X	1889406	Machine Screw, 8-32 x 3/8" long
15	X	X	X	7429700	Moisture Sensor
16	X	X	X	7373450	Vacuum Hose
17	X	X	X	7403800	Filter, Female Luer-Lok
18	X	X	X	7403700	Luer, #10-32 Male
19	X	X	X	7432700	Vacuum Control/Bleed Valve
20	X	X	X	7162300	Vacuum Sensor
21	X			7330400	Electrical Panel Assembly 115V
	X			7330401	Electrical Panel Assembly 230V
		X	X	7330402	Electrical Panel Assembly 115V
		X	X	7330403	Electrical Panel Assembly 230V
22	X	X	X	7515302	Temperature Sensor (Not Shown)
23	X	X	X	1336400	Power Cord 115V 60Hz US (Not Shown)
	X	X	X	1338002	Power Cord 230V 60Hz US (Not Shown)
	X	X	X	1332601	Power Cord 230V 60Hz Saudi (Not Shown)
	X	X	X	1336500	Power Cord 230V 50Hz EU (Not Shown)
	X	X	X	1332701	Power Cord 230V 50Hz China (Not Shown)
	X	X	X	1332601	Power Cord 230V 50Hz UK (Not Shown)
	X	X	X	1345701	Power Cord 230V 50Hz India (Not Shown)
24	X	X	X	7361100	Wire Harness, IOB Control (Not Shown)
25	X			7361200	Wire Harness, Power (Not Shown)
		X	X	7361201	Wire Harness, Power (Not Shown)
26		X	X	7208100	Baffle Collector
27	X	X	X	7205304	Drain Hose (Not Shown)

**4.5L -50C Models (70040xxxx)**  
**4.5L -84C Models (71040xxxx)**  
**4.5L -105C Models (72040xxxx)**

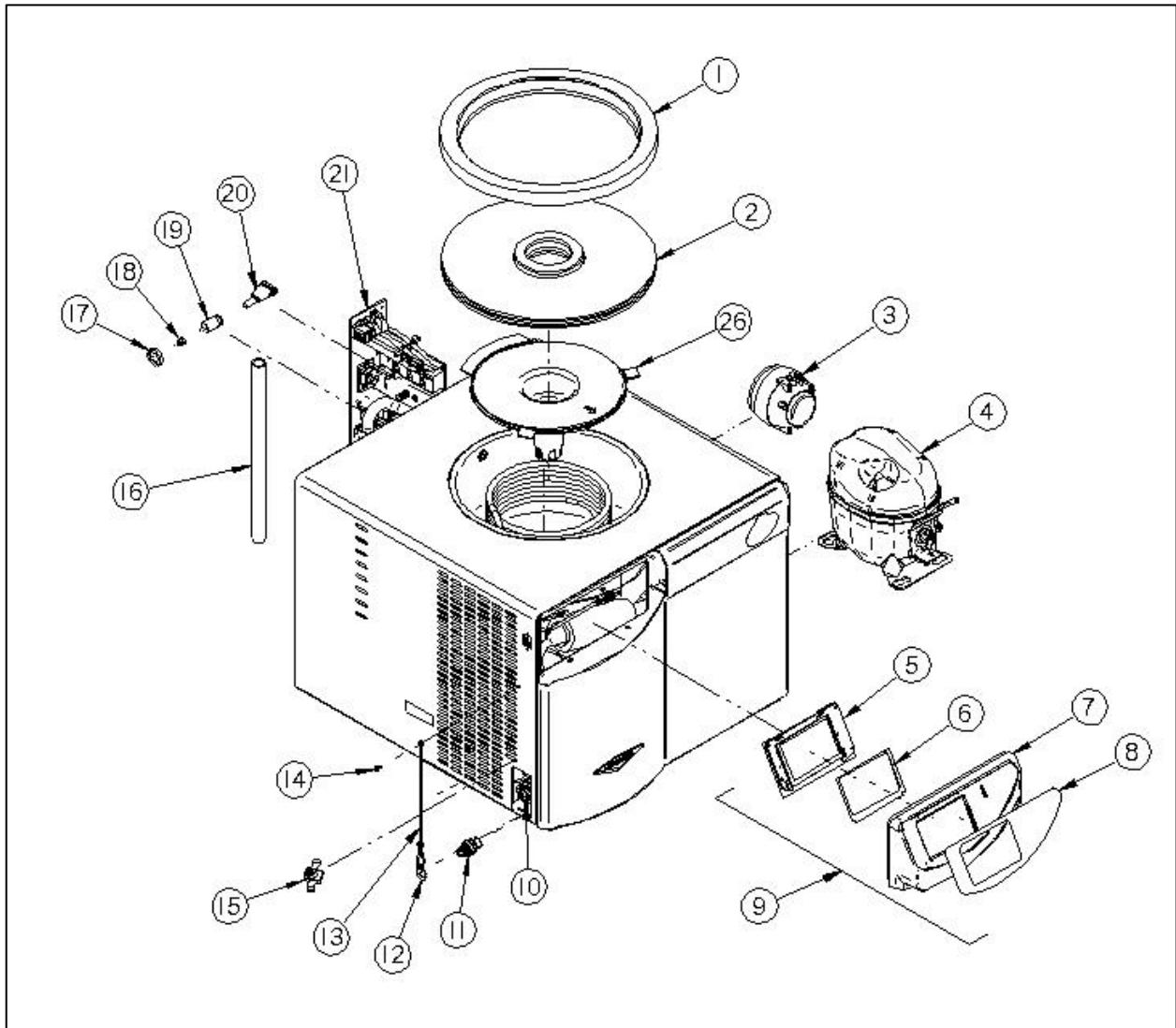

\*4.5L -84C Model Shown

## Appendix A: Freeze Dryer Components

### 8L -50C Models (70080xxxx)

Item	-50C	Part No.	Description
1	X	7690800	Lid Gasket
2	X	7329600	Lid (Acrylic)
3	X	7953802	Motor, Fan, 9 Watt, 115V
	X	7953803	Motor, Fan, 9 Watt, 230V
4	X	7750607	Compressor, 115V, 60Hz
	X	7750606	Compressor, 230V, 50Hz
	X	7750605	Compressor, 230V, 60Hz
5	X	7316600	Display Assembly
6	X	7337300	Gasket, Display
7	X	7337400	Panel, Control
8	X	7336900	Label, Control Panel
9	X	7337600	Control Panel Assembly (Complete)
10	X	7335200	Drain Fitting (Coupling Body)
11	X	7335300	Drain Fitting (Coupling Insert, 3/8 Barb)
12	X	7337100	Retaining Ring, Drain Fitting
13	X	7337000	Lanyard, Drain Fitting
14	X	1889406	Machine Screw, 8-32 x 3/8" long
15	X	7429700	Moisture Sensor
16	X	7373450	Vacuum Hose
17	X	7403800	Filter, Female Luer-Lok
18	X	7403700	Luer, #10-32 Male
19	X	7432700	Vacuum Control/Bleed Valve
20	X	7162300	Vacuum Sensor
21	X	7330400	Electrical Panel Assembly 115V
	X	7330401	Electrical Panel Assembly 230V
22	X	7515302	Temperature Sensor (Not Shown)
23	X	1336400	Power Cord 115V 60Hz US (Not Shown)
	X	1338002	Power Cord 230V 60Hz US (Not Shown)
	X	1332601	Power Cord 230V 60Hz Saudi (Not Shown)
	X	1336500	Power Cord 230V 50Hz EU (Not Shown)
	X	1332701	Power Cord 230V 50Hz China (Not Shown)
	X	1332601	Power Cord 230V 50Hz UK (Not Shown)
	X	1345701	Power Cord 230V 50Hz India (Not Shown)
24	X	7361100	Wire Harness, IOB Control (Not Shown)
25	X	7366800	Wire Harness, Power (Not Shown)
26	X	7205304	Drain Hose (Not Shown)

8L -50C Models (70080xxxx)

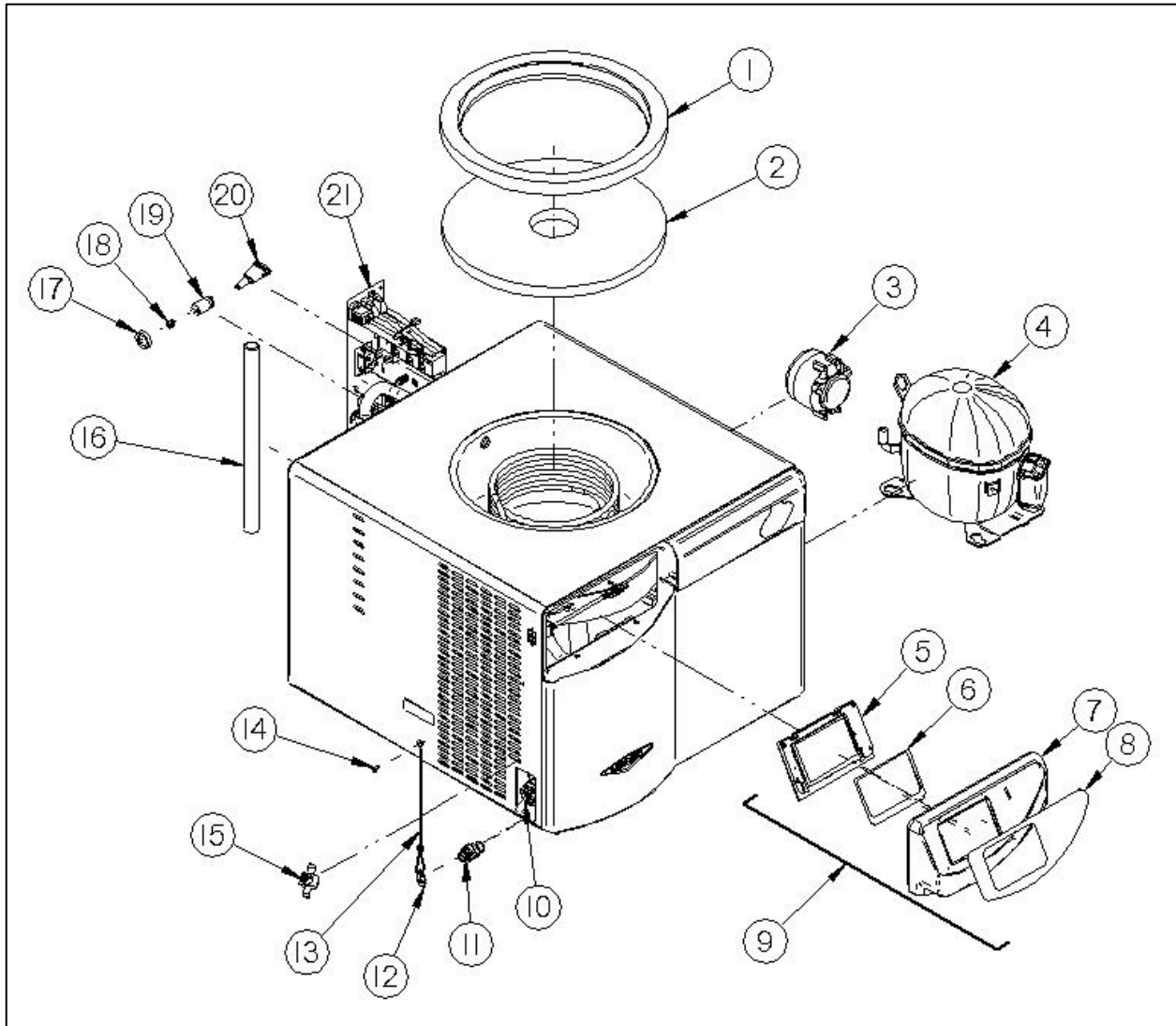



---

# APPENDIX B

## FREEZE DRYER DIMENSIONS

2.5L -50C Models (70020\*\*\*\*)

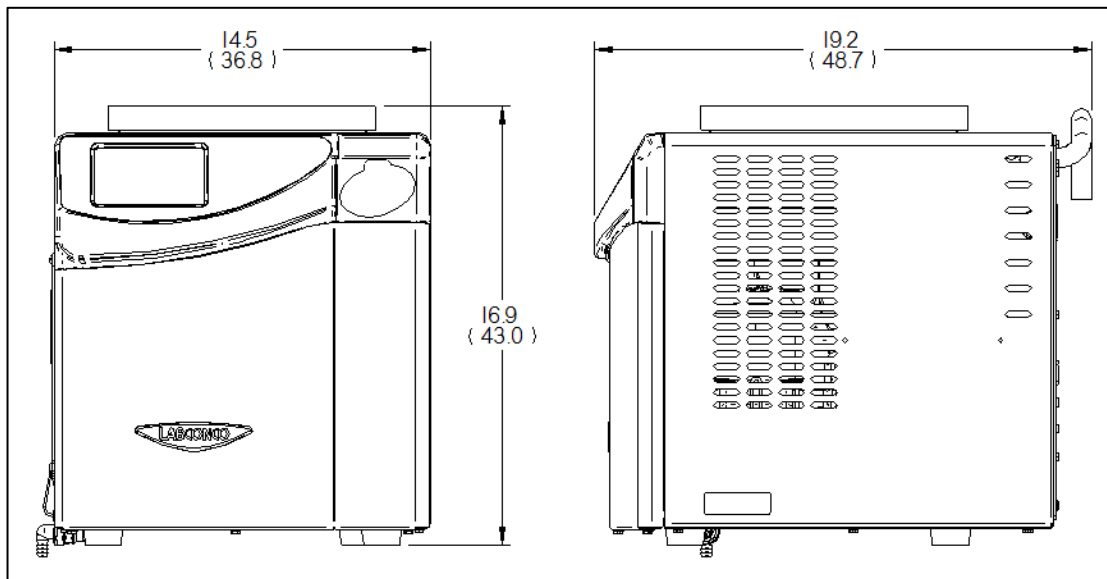

## Appendix B: Freeze Dryer Dimensions

### 2.5L -84C Models (71020\*\*\*\*)

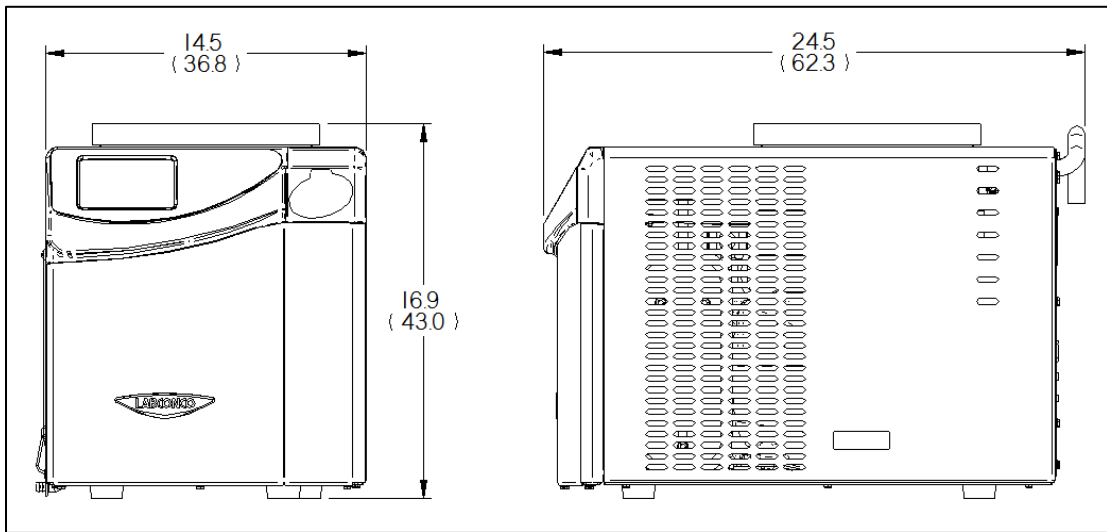

### 4.5L -50C Models (70040\*\*\*\*)

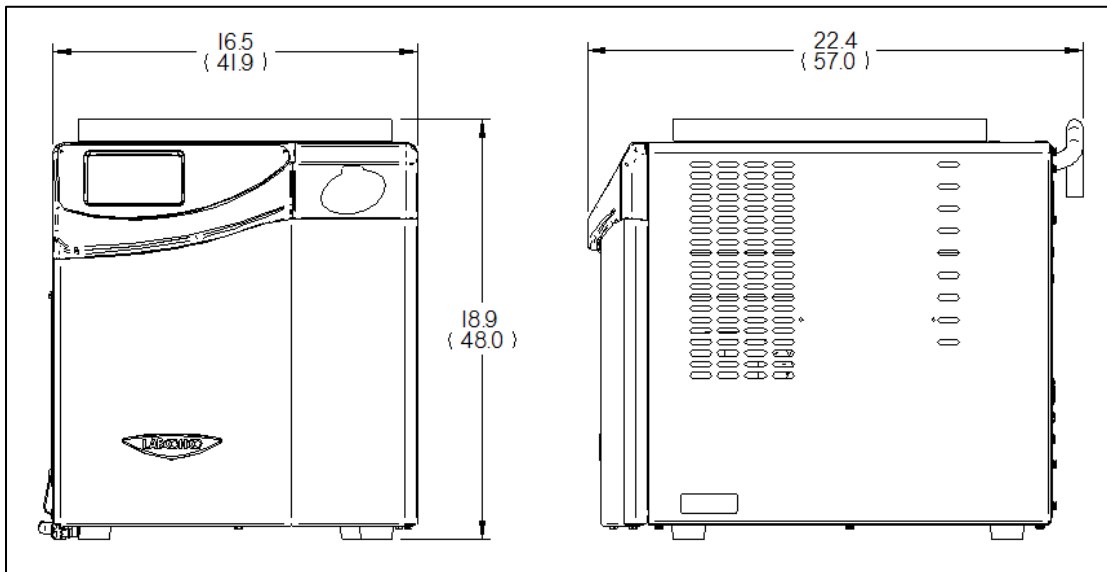

\*Dimensions in inches & (centimeters)

---

**Appendix B: Freeze Dryer Dimensions**

---

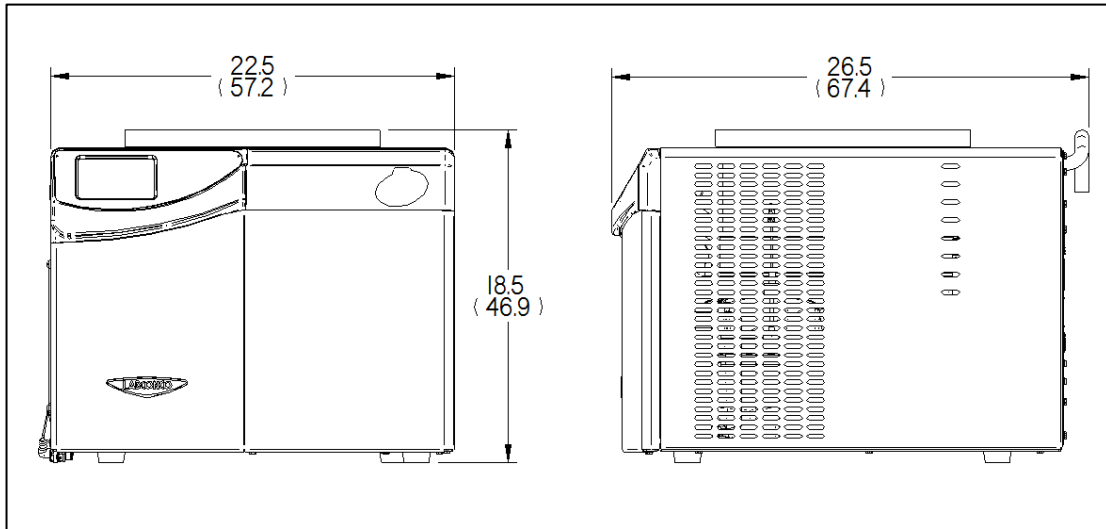
**4.5L -84C Models (71040\*\*\*\*)****4.5L -105C Models (72040\*\*\*\*)****8L -50C Models (70080\*\*\*\*)**

\*Dimensions in inches & (centimeters)

---

# APPENDIX C

## FREEZE DRYER

### SPECIFICATIONS

This Appendix contains technical information about the Freeze Dryer including electrical specifications and operating conditions.

#### Electrical Specifications

Catalog #	Description	Voltage		Frequency	Amps
		Nominal	Operating Range	(Hz)	Max. with Vacuum Pump
70020xxxx	2.5L -50C	115V	103-127	60	14
		230V	187-253	60	7
		230V	198-253	50	7
71020xxxx	2.5L -84C	115V	103-127	60	16
		230V	187-253	60	10
		230V	198-253	50	10
70040xxxx	4.5L -50C	115V	103-127	60	14
		230V	187-253	60	7
		230V	198-253	50	7
71040xxxx	4.5L -84C	115V	103-127	60	16
		230V	187-253	60	10
		230V	198-253	50	10
72040xxxx	4.5L -105C	115V	103-127	60	16
		230V	187-253	60	10
		230V	198-253	50	10
70080xxxx	8L -50C	115V	103-127	60	14
		230V	187-253	60	7
		230V	198-253	50	7

## Environmental Conditions

- Indoor use only.
- Ambient temperature range: 41° to 104°F (5° to 40°C).
- Maximum relative humidity: 80% for temperatures up to 88°F (31°C), decreasing linearly to 50% relative humidity at 104°F (40°C).
- Main supply voltage fluctuations not to exceed  $\pm 10\%$  of the nominal voltage.
- Transient overvoltages according to Installation Categories II (Overvoltage Categories per IEC 1010). Temporary voltage spikes on the AC input line that may be as high as 1500V for 115V models and 2500V for 230V models are allowed.
- Used in an environment of Pollution degrees 2 (i.e., where normally only non-conductive atmospheres are present). Occasionally, however, a temporary conductivity caused by condensation must be expected, in accordance with IEC 664.

---

# APPENDIX D

# FREEZE DRYER ACCESSORIES

Labconco offers a full line of accessories to enhance your Freeze Dryer's operation and usability. For a complete list of these accessories, please consult our website at [www.labconco.com](http://www.labconco.com).