

REV	ECO	DESCRIPTION	DATE	DRFT	CHKD
C	12488	UPDATED	10/01/14	LS	BP

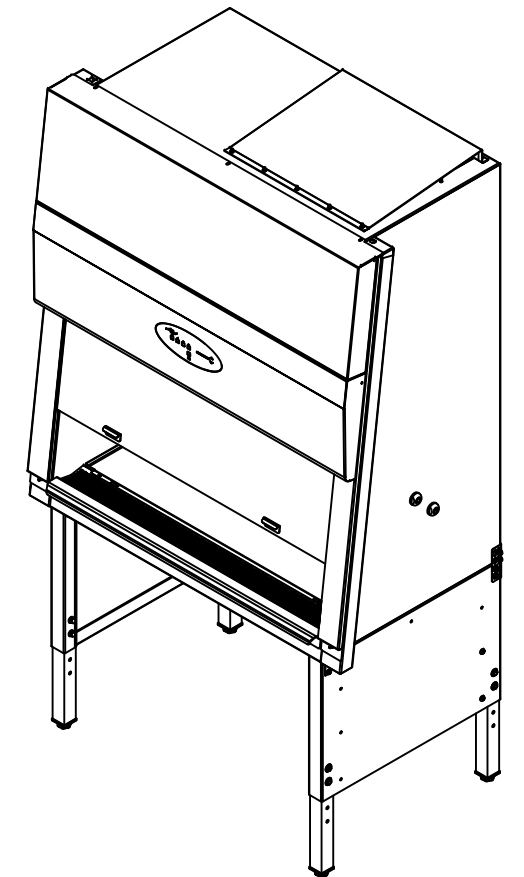
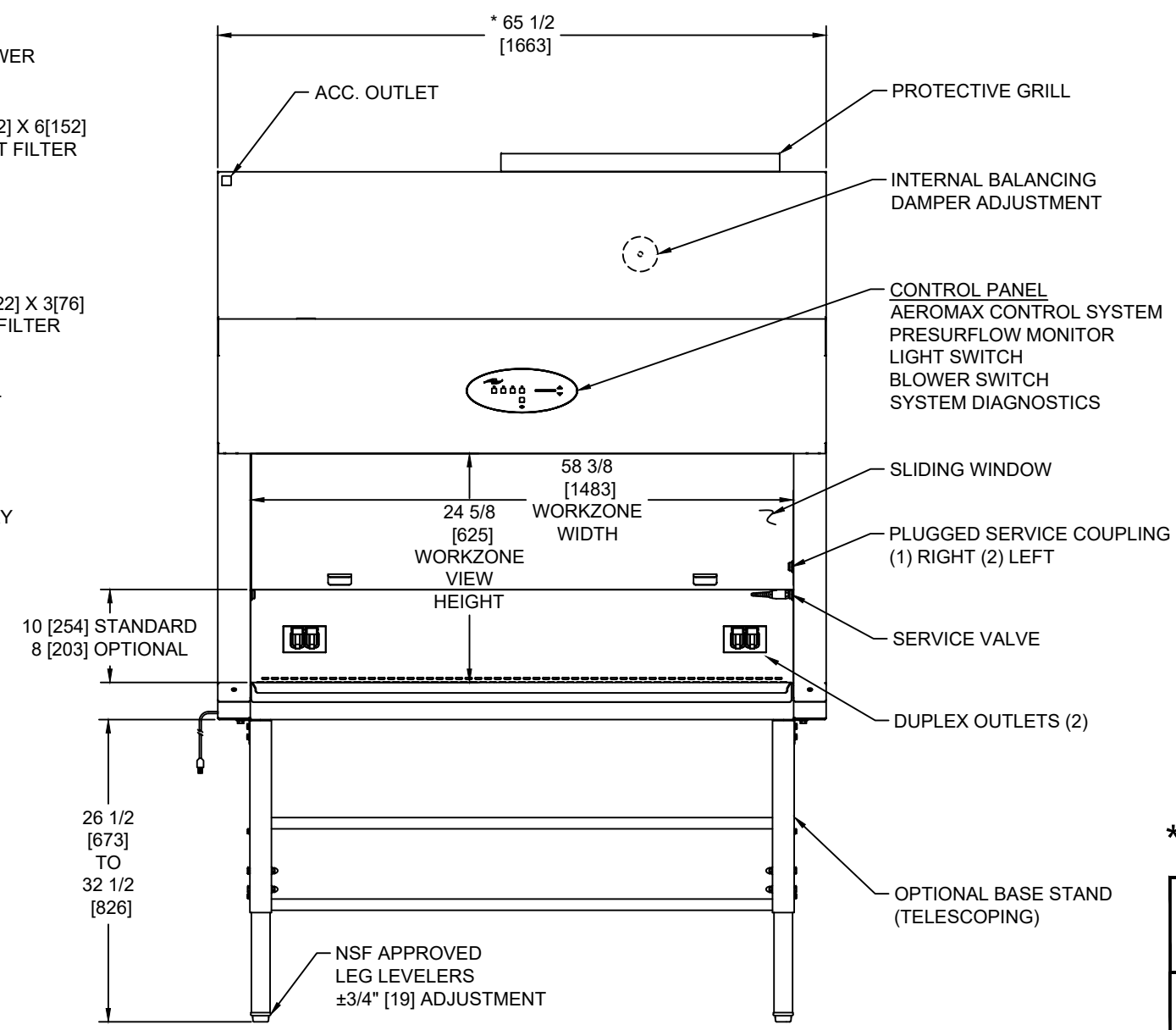
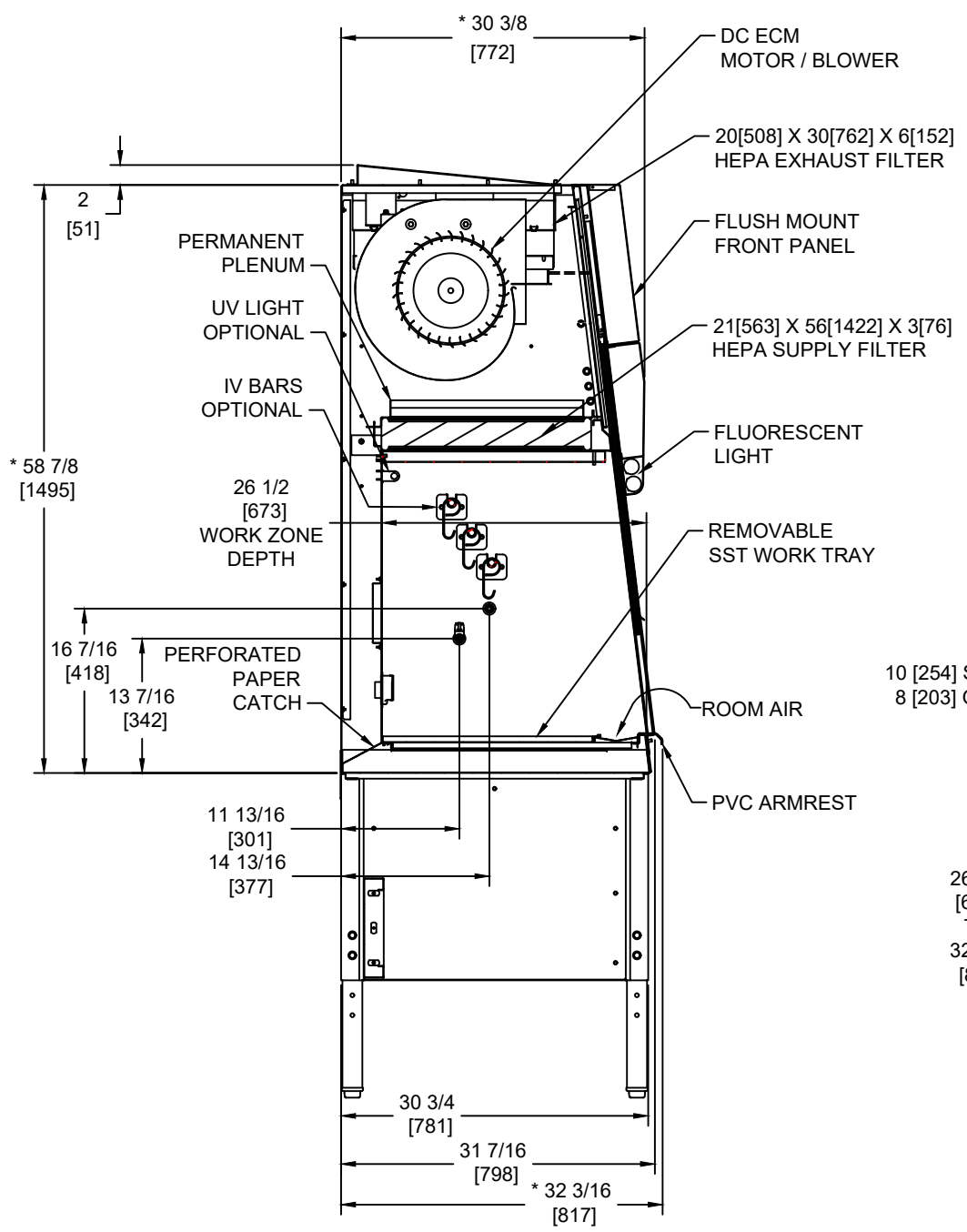
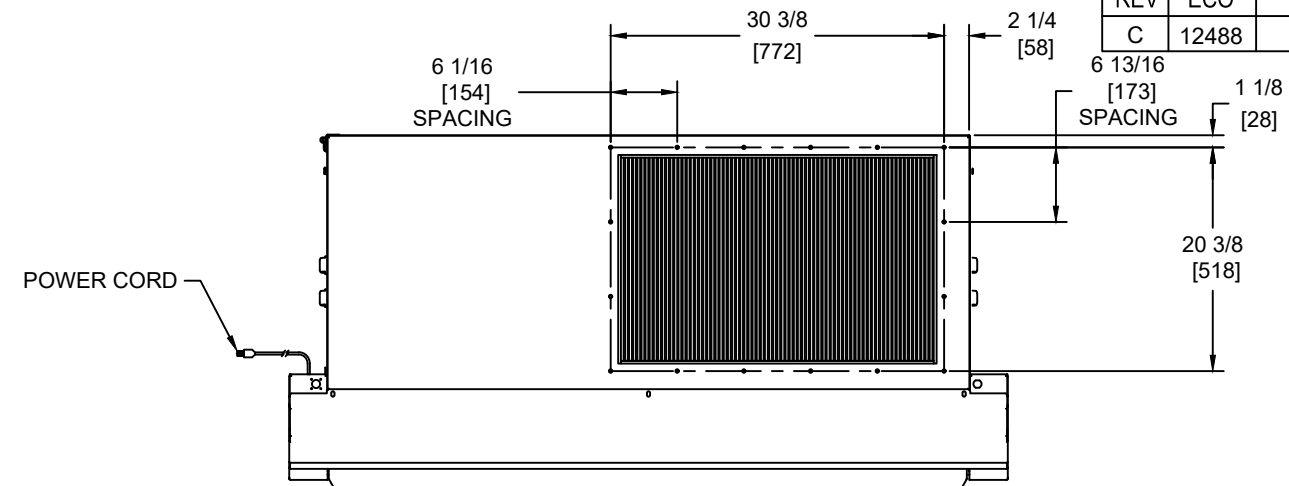

* OVERALL DIMENSIONAL TOLERANCE ±1/4 [6.35]
ALL OTHER DIMENSIONS ±1/8 [3.17]

NU-540-500 CLASS II, TYPE A2 (ENERGY SAVER) BIOLOGICAL SAFETY CABINET					
DFTM	LS	12/16/2013	CHKD	BP	SHEET 1 OF 1
DRAWING NUMBER		BCD-16515		C	

INCH
MILLIMETER

REV	ECO	DESCRIPTION	DATE
C	12488	UPDATED	10/01/14

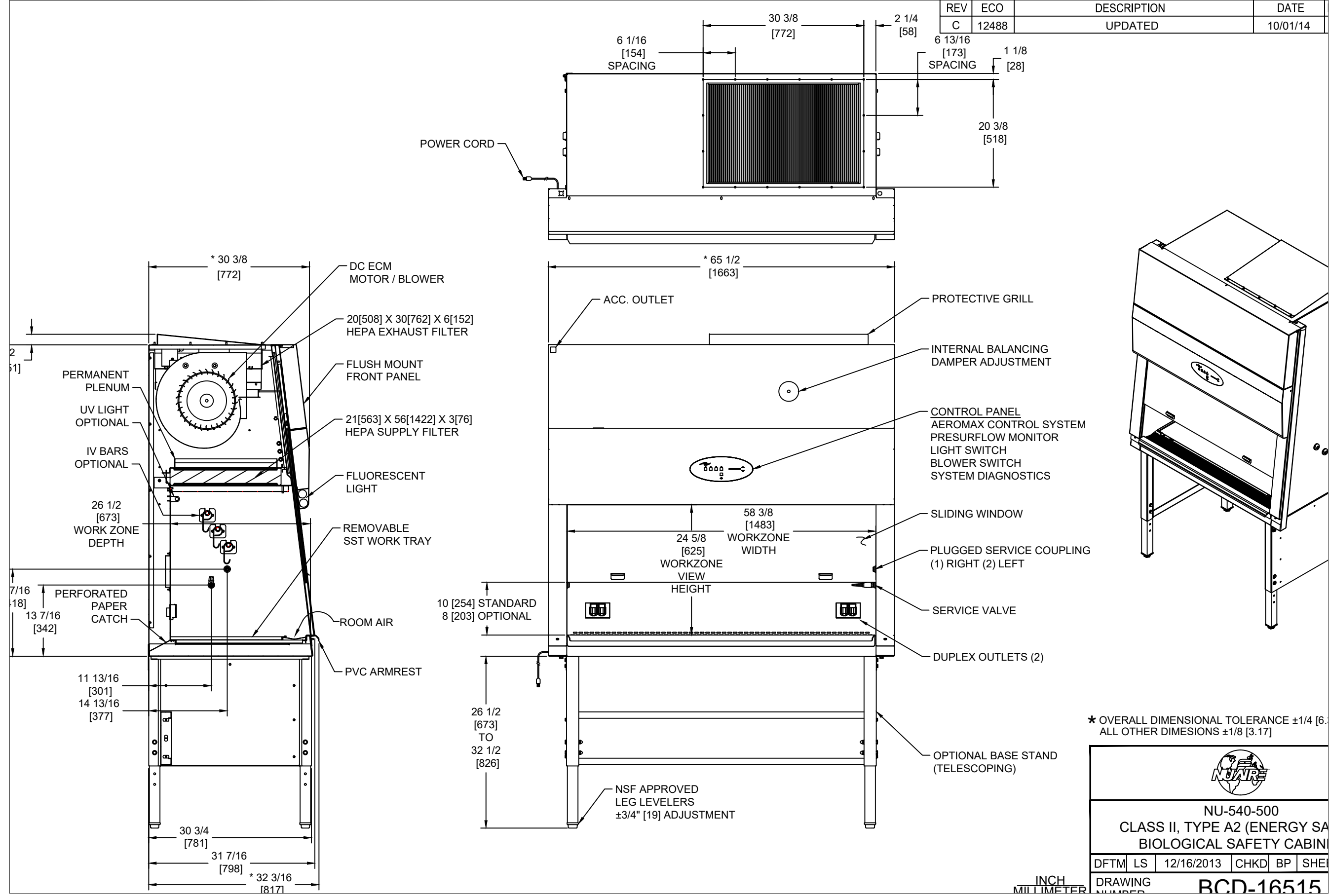

* OVERALL DIMENSIONAL TOLERANCE ±1/4 [6.3] ALL OTHER DIMENSIONS ±1/8 [3.17]

NU-540-500				
CLASS II, TYPE A2 (ENERGY SAVING) BIOLOGICAL SAFETY CABINET				
DFTM	LS	12/16/2013	CHKD	BP
DRAWING NUMBER				BCD-16515

INCH MILLIMETER

REV	ECO	DESCRIPTION	DATE
C	12488	UPDATED	10/01/14

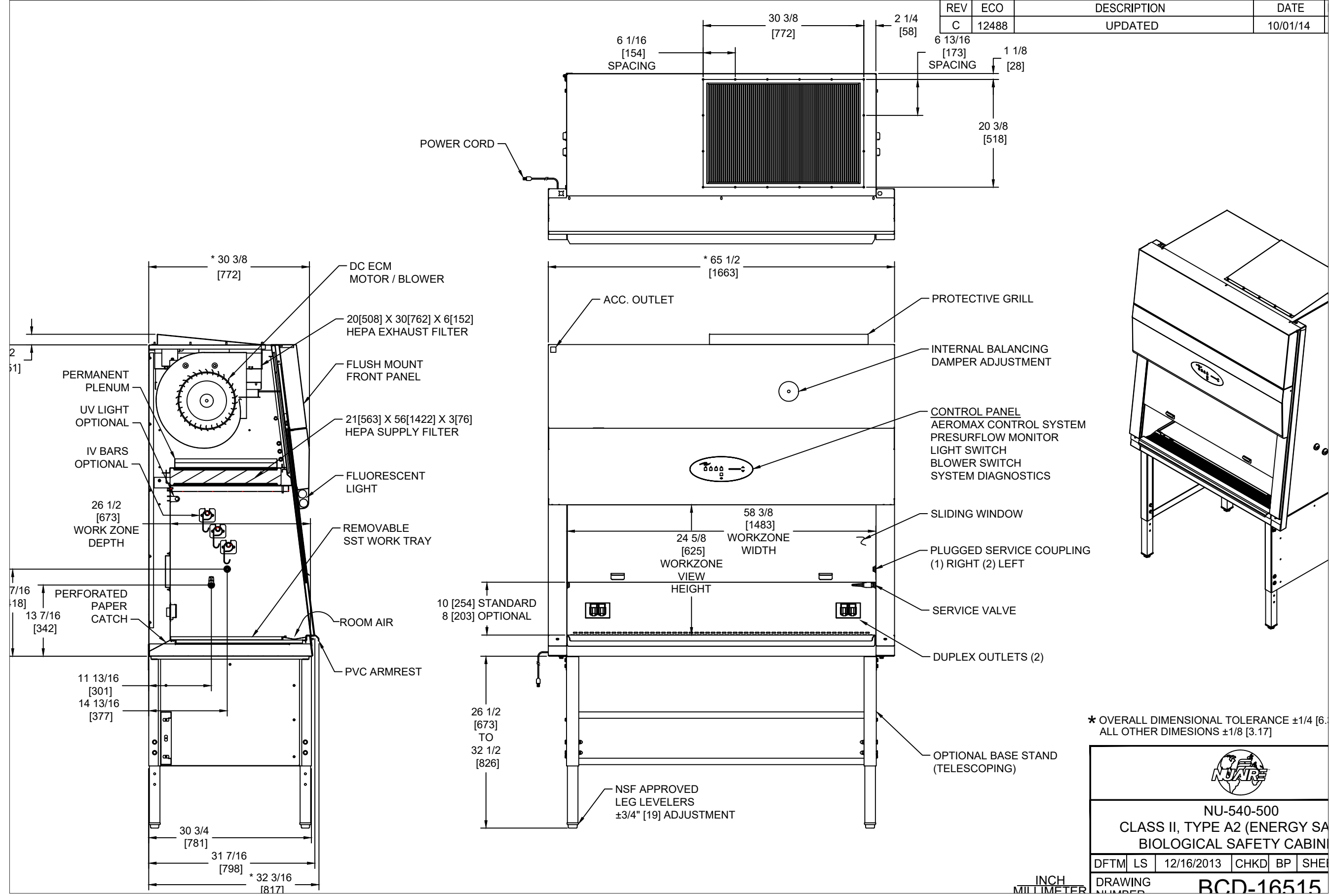

* OVERALL DIMENSIONAL TOLERANCE ±1/4" [6.35]
ALL OTHER DIMENSIONS ±1/8" [3.17]



NU-540-500
CLASS II, TYPE A2 (ENERGY SAVING)
BIOLOGICAL SAFETY CABINET

DFTM	LS	12/16/2013	CHKD	BP	SHE
DRAWING NUMBER					BCD-16515

INCH
MILLIMETER