

- ⚠ CAUTION! Do not lift your MULTI VORTEX-GENIE® Shaker by the clamping platform.
- ⚠ CAUTION! Failure to follow operating instructions can compromise the user's safety.
- ⚠ CAUTION! Unplug from power before cleaning. Do not immerse

**Care and Handling**

Your MULTI VORTEX-GENIE Shaker should be given the care normally required for any electrical appliance. Avoid wetting or unnecessary exposure to fumes. The finish can be washed with water (after unplugging) and soap or detergents, using a cloth or sponge. Keep the unit clean by immediately blotting any spills. Replacement parts are available through your laboratory equipment distributor or directly from Scientific Industries. Refer to "Parts Assembly List".

**Parts Assembly List**

To order parts for the MULTI VORTEX-GENIE Shaker:

Contact your local distributor or visit [www.scientificindustries.com](http://www.scientificindustries.com). Please specify Part No., quantity and electric voltage.

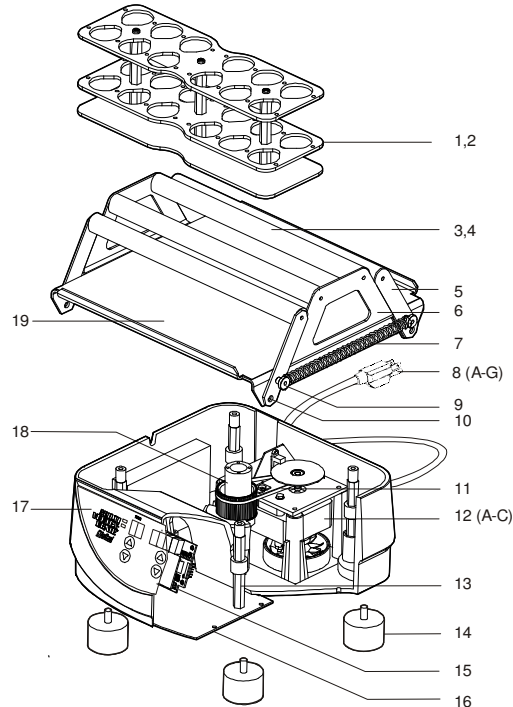

Indicator No.	Part No.	Description	Indicator No.	Part No.	Description
1	SI-M010	(1) 12-Pack Multi-Tube Rack	9	NTP0010	Thumb Nut
2	SI-M020	(2) 12-Pack Multi-Tube Racks	10	SCP0060	Pivot Bolt
3	0M-M236-205	Rod	11	HWP0064	Timing Belt
4	0M-M236-206	Foam	12A	0A-M236-021	Motor 120V Assembly
5	0M-M236-201	Arm	12B	0A-M246-021	Motor 230V Assembly
6	0M-M236-200	Platform	12C	0A-M286-021	Motor 100V Assembly
7	SPP0005	Spring, Extension	13	0A-M236-002	Shock Mount Assembly
8A	318-0510-02	120V Line Cord	14	0K-M236-907	Feet (4)
8B	0K-0246-901	230V Line Cord, No Plug	15	EBP0002	Digital Timer Board
8C	0K-0256-901	230V Line Cord, Euro Plug	16	0M-M236-204	Base Plate
8D	0K-0266-901	230V Line Cord, British Plug	17	EL-M236-575	Control Panel
8E	0K-0276-901	230V Line Cord, Swiss Plug	18	0K-M236-001	Bearing Assembly
8F	0K-0286-901	100V Line Cord	19	0M-M236-207	Rubber Pad
8G	ECP0021	Australian Plug (only)			

# MULTI VORTEX-GENIE®

## LARGE CAPACITY SHAKER

### OPERATING INSTRUCTIONS

Models SI-M236 through SI-M296



80 Orville Drive, Suite 102, Bohemia, NY 11716 U.S.A.  
 Phone: (631) 567-4700 • Toll Free: 888-850-6208  
 Customer Service: [custsvc@scientificindustries.com](mailto:custsvc@scientificindustries.com)  
[www.scientificindustries.com](http://www.scientificindustries.com)

The **MULTI VORTEX-GENIE®** is a large capacity, shaker that provides the same true vortexing as the **ORIGINAL VORTEX-GENIE® 2**. Speed and time are digitally controlled for reproducibility and accuracy, with true speed display. **VORTEX-GENIE®** mixers are the "Gold Standard" for laboratory mixers. The quality and reliability, that you have come to know so well, are characteristics that are, by design, an integral part of all "GENIE™" products.

## OPERATING INSTRUCTIONS

We recommend you retain the original packaging for 90 days in case you need to return the product for any reason to your distributor or Scientific Industries.

1.0 – Plug the line cord into a properly grounded electrical outlet. (**120 VAC for the SI-M236 model; 230 VAC for the SI-M246-SI-M276 and SI-M296 models; 100 VAC for the SI-M286 model**). Illuminated numbers will appear in the **TIME** and **SPEED** windows indicating that the unit is ON and ready for use.

1.1 – The work surface on which the shaker is placed must be level, stable and non-slip.

1.2 – Secure the vessels to be mixed, within the spring loaded rotating rods. Using your thumb, rotate the rod until there is sufficient space to place the vessels on the platform (see Figure 1). If required, the rod can be rotated past horizontal to lock in an opened position (see Figure 2). Place the vessels so that they do not touch each other and are seated firmly against the stationary rod in the center of the clamping platform. Release the rotated rod and be sure that the vessels are securely locked in place.

Figure 1



Figure 2



1.3 – Position vessels to be mixed, evenly distributed on the clamping platform. Uneven loading may result in excessive vibrating of the shaker and support table. Should this occur, reduce the mixing speed or turn the shaker off and redistribute the load of the vessels. The clamping platform can accommodate up to six 250mL vessels (more for smaller vessels) or two 12-Pack Multi-Tube Racks. The 12-Pack Multi-Tube Racks (set of 2) can accommodate up to 24 tubes of any kind of material up to 29mm diameter (50mL centrifuge tube). In most instances, tubes without caps may be mixed with proper speed control. Tubes must be capped when potential aerosols may be hazardous. It is very important to regularly monitor mixing cycles to ensure that the vessels remain firmly secure.

2.0 - The **MULTI VORTEX-GENIE®** Shaker has three modes of operation: "TIMED", "CONTINUOUS" and "SLEEP".

2.1 – "TIMED"

To initiate a timed mixing cycle, press the UP/DOWN arrow button beneath the **TIME** window to set the desired cycle time from 1-99 minutes. Next, set the speed control by pressing the UP/DOWN arrow beneath the **SPEED** window to any value between 250 and 1000RPM (up to 950RPM for 50Hz models). A setting of 250RPM is the least vigorous mixing and 1000RPM is the most vigorous mixing. Press the **START/STOP** button to begin the mixing action. The shaker will gently ramp up to speed and run until the set time has elapsed. To stop the cycle before the set time has elapsed, press the **START/STOP** button. To initiate a new timed cycle, press the **START/STOP** button again. The speed control can be adjusted up or down during the mixing cycle, however, the **TIME** can only be adjusted before the cycle begins. Mixing cycles are precisely timed and you may initiate as many mixing cycles as you wish.

2.2 – "CONTINUOUS"

To initiate the "CONTINUOUS" mode, press and hold the DOWN arrow button beneath the **TIME** window until the illuminated display reaches "0". Upon releasing the button, the display will have two dash marks (--), indicating that **no time limit** is set. Set the speed by pressing the UP/DOWN arrow buttons beneath the **SPEED** window (see 2.1 above). Press the **START/STOP** button to begin the mixing action.

2.3 – "SLEEP"

The shaker will automatically go into a "SLEEP" mode if the shaker is plugged in but not used for 10 minutes. The **TIME** and **SPEED** illuminated displays will go blank and the **MIN** illuminated display will blink. Press the **START/STOP** button to "WAKE UP" the shaker.

## SPECIFICATIONS

The **MULTI VORTEX-GENIE** Shaker is classified as "Installation Category 2"

Environmental: 0°C – 38°C (32°F-100°F), 95% Humidity max.

MODEL	POWER REQUIRED	AMPS
SI-M236	120V	0.65
SI-M246	230V	0.5
SI-M256	230V	0.5
SI-M266	230V	0.5
SI-M276	230V	0.5
SI-M296	230V	0.5
SI-M286	100V	1.0

Weight: 11.3 Kg (25 lbs) - Cast metal base with vibration damping feet.

Base Dimensions: (DxWxH) 310 x 270 x 195mm (12.2 x 10.6 x 7.7in)

Orbit: 4mm diameter (same as **VORTEX-GENIE®**)