

# VirTis Ultra 35L

Pilot Lyophilizer



(Standard configuration Ultra 35L shown)

## Key Features

- Compact design for easy installation.
- Single product chamber design allows for larger batches and product uniformity.
- Available with a Wizard 2.0, Encore or Maestro control system.
- Optional hydraulic stoppering system available.
- Cleanroom configuration available.

## Performance Specifications

Item	Super ES	Super XL	EL
Shelf Temperature Control Range (°C) <sup>§</sup>	-40 to 65	-40 to 65	-55 to 65
Lowest Shelf Temperature (50 Hz / 60 Hz, °C)	-43 / -46	-57 / -60	-67 / -70
Lowest Condenser Temperature (50 Hz / 60 Hz, °C)	-50 / -53	-67 / -70	-82 / -85
Maximum Condenser Capacity (L)	35	35	35
Condenser Surface Area (in <sup>2</sup> / cm <sup>2</sup> )	750 / 4838	750 / 4838	750 / 4838
Maximum Ice Condensing Capacity in 24 hours (L) <sup>†</sup>	20	20	20
Maximum Deposition Rate (L/hour) <sup>†</sup>	0.83	0.83	0.83
Condenser Pull-Down from 20 °C to -45 °C (minutes)	≤ 18	≤ 25	≤ 25
Shelf Pull-Down from 20 °C to -40 °C (minutes) <sup>††</sup>	≤ 90	≤ 90	≤ 60
Number of Compressors	1	1	2
Compressor Horsepower	1.5	1.5	1.5, 1.5
System Refrigerant	MO 89	R245fa / R508B	R508B, R407C
Vacuum Time to 100 Millitorr (minutes) <sup>‡</sup>	≤ 30	≤ 30	≤ 30
Vacuum Rate of Rise (mT/hour) <sup>‡</sup>	≤ 30	≤ 30	≤ 30
Volume-Based Leak Rate (mbar-L/sec) <sup>‡</sup>	≤ .0036	≤ .0036	≤ .0036
Lowest System Vacuum (mT) <sup>‡‡</sup>	≤ 15	≤ 15	≤ 15
Temperature Uniformity (°C) <sup>¶</sup>	± 1.0	± 1.0	± 1.0

**Note:** Performance specifications are based on SP Scientific test data from units operating at an ambient room temperature of approximately 20 °C. SP Scientific recommends an operating range of 15-25 °C (59-77 °F).

## Electrical Requirements

	208/240	208/230	400
Voltage (VAC) <sup>*</sup>	208/240	208/230	400
Hertz <sup>*</sup>	50, 60	60	50
Phase <sup>*</sup>	1	3	3
Breaker Amperage <sup>*</sup>	40	40	30
Recommended Outlet	NEMA 6-50R	N/A	N/A

## Utility Requirements

Item	Super ES	Super XL	EL
Compressed Air (psig)	80	80	80
Ambient Room Temperature (°C)	20	20	20
<b>Air-Cooled Units</b>			
Approx. Peak Heat Generated (BTU/h)	14,000	14,000	17,800
<b>Water-Cooled Units</b>			
Approx. Peak Heat Generated (BTU/h)	4,500	4,500	4,900
Cooling Water Usage (gpm / lpm) <sup>‡</sup>	1-3 / 4-12	1-3 / 4-12	1-3 / 4-12

# Standard Layout Drawings

# Ultra 35L

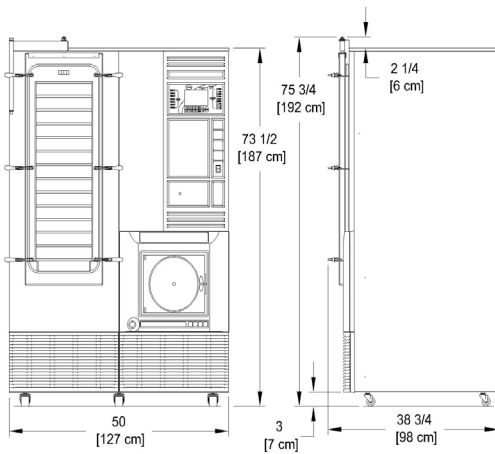

**Standard Configuration**

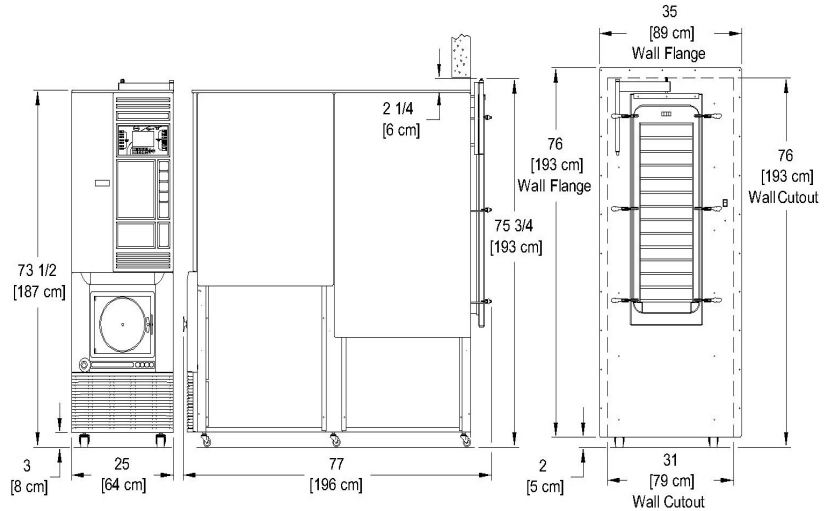

**Cleanroom Configuration**

## Dimensional Data

	Standard Configuration	Cleanroom Configuration
Width (in / cm)	50 / 127	25 / 64
Depth (in / cm)	38.75 / 98	77 / 196
Height (in / cm)	75.75 / 193	75.75 / 193
Approximate Weight (lb / kg)	2000 / 909	2000 / 909
Minimum Clearance on All Sides (in / cm)	10 / 25.4	10 / 25.4

**Note:** SP Scientific recommends a 24-inch clearance around all sides of the unit for serviceability.

## Shelf Configuration

Number of Shelves	Shelf Area (ft <sup>2</sup> / m <sup>2</sup> )	Shelf Clearance (in / mm)	
		Bulk Drying	Hydraulic Stopping
4 Shelves	6.12 / 0.57	8.88 / 225	8.44 / 214
5 Shelves	7.65 / 0.71	7.03 / 178	6.68 / 169
6 Shelves	9.18 / 0.85	5.79 / 146	5.51 / 139
7 Shelves	10.71 / 1.00	4.91 / 124	4.67 / 118
8 Shelves	12.24 / 1.14	4.25 / 107	4.04 / 102
9 Shelves	13.77 / 1.28	3.74 / 94	3.55 / 89
10 Shelves	15.30 / 1.42	3.33 / 84	3.15 / 79
11 Shelves	16.83 / 1.56	2.99 / 75	2.83 / 71
12 Shelves	18.36 / 1.71	2.71 / 68	2.56 / 64
13 Shelves	19.89 / 1.85	2.47 / 62	2.34 / 59
14 Shelves	21.43 / 1.99	2.27 / 57	2.14 / 54
15 Shelves	22.96 / 2.13	2.09 / 53	1.97 / 50
Shelf Size (W x D, in / mm): 10.75 x 20.5 / 273 x 521			

## Additional Information

Construction	316L Stainless Steel Shelves, Product Chamber and Condenser Chamber
Vacuum Pump	Alcatel 2015SD Two-Stage Rotary Vane
Stoppinging	Bottom-Up Hydraulic
Defrost Type	Hot Gas
Refrigerant Type	CFC Free
Vapor Port	Six (6) Inches

\* VirTis units are highly customizable and SP Scientific can configure any unit to conform to the service requirements of a wide range of international voltage and phase configurations. Contact SP Scientific for more information.

<sup>†</sup> The specified Maximum Ice Condensing Capacity in 24 Hours and Maximum Deposition Rate are based on the process of freeze-drying water as aggressively as possible. The freeze dryer's ability to collect ice at an hourly rate or over a specified period will always be application dependent.

<sup>‡</sup> Cooling water temperatures should not exceed 24 °C.

<sup>§</sup> Shelf temperature controlled to within ± 0.5 °C of the setpoint within the Shelf Temperature Control Range.

<sup>¶</sup> Shelf Pull-Down times are based on units with one (1) to eight (8) shelves. The increased mass of stainless steel and additional heat transfer fluid required for nine (9) or more shelves increases pull-down time. Use the following multipliers when determining the pull-down time specification for the following shelf configurations:

9-shelf units, standard pull-down time x 1.13	12-shelf units, standard pull-down time x 1.5	15-shelf units, standard pull-down time x 1.88
10-shelf units, standard pull-down time x 1.25	13-shelf units, standard pull-down time x 1.63	
11-shelf units, standard pull-down time x 1.38	14-shelf units, standard pull-down time x 1.75	

<sup>||</sup> Shelf temperature deviations shall not exceed the specification relative to the mean of the highest and lowest temperature readings.

<sup>∞</sup> Vacuum specifications are based on SP Scientific test data from similar units equipped with an Alcatel 2015SD two-stage rotary vane vacuum pump. Units equipped with other vacuum pumps may yield different results.

# VirTis Ultra 50L

Pilot Lyophilizer



(Cleanroom configuration Ultra 50L shown)

## Key Features

- Compact design for easy installation.
- Single product chamber design allows for larger batches and product uniformity.
- Available with a Wizard 2.0, Encore or Maestro control system.
- Optional hydraulic stoppering system available.
- Narrow and Cleanroom configurations available.

## Performance Specifications

Item	XL	EL
Shelf Temperature Control Range (°C) <sup>§</sup>	-40 to 65	-55 to 65
Lowest Shelf Temperature (50 Hz / 60 Hz, °C)	-57 / -60	-67 / -70
Lowest Condenser Temperature (50 Hz / 60 Hz, °C)	-67 / -70	-82 / -85
Maximum Condenser Capacity (L)	50	50
Condenser Surface Area (ft <sup>2</sup> / m <sup>2</sup> )	10 / 0.93	10 / 0.93
Maximum Ice Condensing Capacity in 24 hours (L) <sup>†</sup>	20	20
Maximum Deposition Rate (L/hour) <sup>†</sup>	0.83	0.83
Condenser Pull-Down from 20 °C to -45 °C (minutes)	≤ 25	≤ 35
Shelf Pull-Down from 20 °C to -40 °C (minutes) <sup>¶</sup>	≤ 90	≤ 60
Number of Compressors	1	2
Compressor Horsepower	3.5	3.5, 1.5
System Refrigerant	R245fa / R508B	R508B, R407C
Vacuum Time to 100 Millitorr (minutes) <sup>††</sup>	≤ 45	≤ 45
Vacuum Rate of Rise (mT/hour) <sup>††</sup>	≤ 30	≤ 30
Volume-Based Leak Rate (mbar-L/sec) <sup>††</sup>	≤ .0042	≤ .0042
Lowest System Vacuum (mT) <sup>††</sup>	≤ 15	≤ 15
Temperature Uniformity (°C) <sup>  </sup>	± 1.0	± 1.0

Note: Performance specifications are based on SP Scientific test data from units operating at an ambient room temperature of approximately 20 °C. SP Scientific recommends an operating range of 15-25 °C (59-77 °F).

## Electrical Requirements

	XL		EL	
	208/240	208/230	208/240	400
Voltage (VAC) <sup>*</sup>	208/240	208/230	208/240	400
Hertz <sup>*</sup>	50, 60	60	50, 60	50
Phase <sup>*</sup>	1	3	1	3
Breaker Amperage <sup>*</sup>	40	30	50	30
Recommended Outlet	NEMA 6-50R	N/A	NEMA 6-50R	N/A

## Utility Requirements

Item	XL	EL
Compressed Air (psig)	80	80
Ambient Room Temperature (°C)	20	20
<b>Air-Cooled Units</b>		
Approx. Peak Heat Generated (BTU/h)	19,100	22,900
<b>Water-Cooled Units</b>		
Approx. Peak Heat Generated (BTU/h)	5,000	5,400
Cooling Water Usage (gpm / lpm) <sup>‡</sup>	2-5 / 8-19	2-5 / 8-19

# Cleanroom Layout Drawing

# Ultra 50L

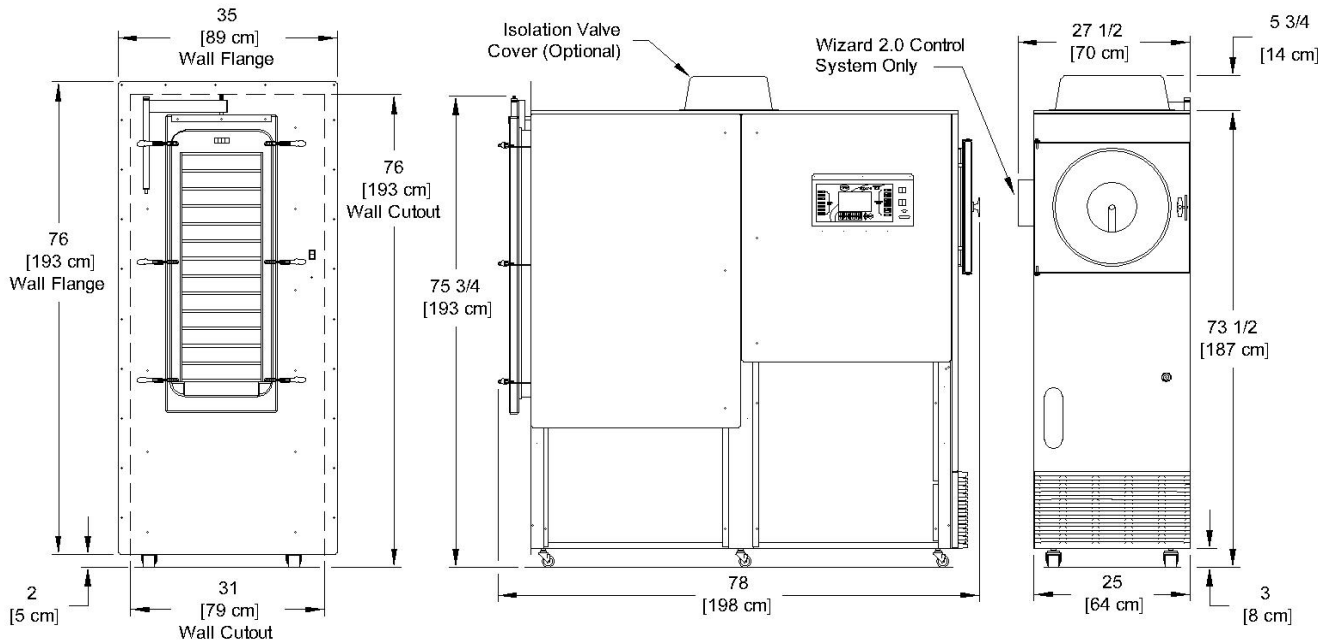

## Dimensional Data

	Narrow Configuration	Cleanroom Configuration
Width (in / cm)	25 / 64	25 / 64
Depth (in / cm)	78 / 198	78 / 198
Height (in / cm)**	75.75 / 193	75.75 / 193
Approximate Weight (lb / kg)	2000 / 909	2000 / 909
Minimum Clearance on All Sides (in / cm)	10 / 25.4	10 / 25.4

**Note:** SP Scientific recommends a 24-inch clearance around all sides of the unit for serviceability.

## Additional Information

Construction	316L Stainless Steel Shelves, Product Chamber and Condenser Chamber
Vacuum Pump	Alcatel 2021SD Two-Stage Rotary Vane
Stoppering	Bottom-Up Hydraulic
Defrost Type	Hot Gas
Refrigerant Type	CFC Free
Vapor Port	Eight (8) Inches

## Shelf Configuration

Number of Shelves	Shelf Area (ft <sup>2</sup> / m <sup>2</sup> )	Shelf Clearance (in / mm)	
		Bulk Drying	Hydraulic Stoppering
4 Shelves	6.12 / 0.57	8.88 / 225	8.44 / 214
5 Shelves	7.65 / 0.71	7.03 / 178	6.68 / 169
6 Shelves	9.18 / 0.85	5.79 / 146	5.51 / 139
7 Shelves	10.71 / 1.00	4.91 / 124	4.67 / 118
8 Shelves	12.24 / 1.14	4.25 / 107	4.04 / 102
9 Shelves	13.77 / 1.28	3.74 / 94	3.55 / 89
10 Shelves	15.30 / 1.42	3.33 / 84	3.15 / 79
11 Shelves	16.83 / 1.56	2.99 / 75	2.83 / 71
12 Shelves	18.36 / 1.71	2.71 / 68	2.56 / 64
13 Shelves	19.89 / 1.85	2.47 / 62	2.34 / 59
14 Shelves	21.43 / 1.99	2.27 / 57	2.14 / 54
15 Shelves	22.96 / 2.13	2.09 / 53	1.97 / 50

Shelf Size (W x D, in / mm): 10.75 x 20.5 / 273 x 521

\* VirTis units are highly customizable and SP Scientific can configure any unit to conform to the service requirements of a wide range of international voltage and phase configurations. Contact SP Scientific for more information.

† The specified Maximum Ice Condensing Capacity in 24 Hours and Maximum Deposition Rate are based on the process of freeze-drying water as aggressively as possible. The freeze dryer's ability to collect ice at an hourly rate or over a specified period will always be application dependent.

‡ Cooling water temperatures should not exceed 24 °C.

§ Shelf temperature controlled to within ± 0.5 °C of the setpoint within the Shelf Temperature Control Range.

¶ Shelf Pull-Down times are based on units with one (1) to eight (8) shelves. The increased mass of stainless steel and additional heat transfer fluid required for nine (9) or more shelves increases pull-down time. Use the following multipliers when determining the pull-down time specification for the following shelf configurations:

9-shelf units, standard pull-down time x 1.13	12-shelf units, standard pull-down time x 1.5	15-shelf units, standard pull-down time x 1.88
10-shelf units, standard pull-down time x 1.25	13-shelf units, standard pull-down time x 1.63	
11-shelf units, standard pull-down time x 1.38	14-shelf units, standard pull-down time x 1.75	

|| Shelf temperature deviations shall not exceed the specification relative to the mean of the highest and lowest temperature readings.

\*\* The optional isolation valve adds 5.75 inches to overall height.

†† Vacuum specifications are based on SP Scientific test data from similar units equipped with an Alcatel 2021SD two-stage rotary vane vacuum pump. Units equipped with other vacuum pumps may yield different results.